



- **Montaggio su tubi tondi con preforo**
- **Fornito preassemblato pronto per una semplice installazione**

- Installation on holed round pipes
- Supplied pre-assembled ready to be easily installed

Materiale

Material

Ugello - Nozzle

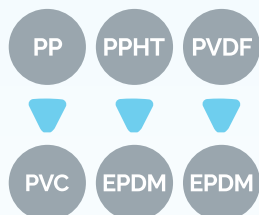

Adattatore - Adaptor

Modello Model	Fessura Slot width mm
PTLT	0,25 - 0,50 - 0,80 - 1,00 - 2,00 - 3,00
TTLT	0,25 - 0,40 - 0,50
RTL	0,20 - 0,25 - 0,30 - 0,35 - 0,50 - 0,60 - 1,00 - 2,00 - 3,00 - 5,00
D4TL	0,15 - 0,20 - 0,25 - 0,50

ORDINE - ORDER				
Modello Model	Fessura Slot width	Ø T - Diametro tubazione Pipe diameter	L2 mm	Materiale Material
RTL	0,25	90	120	PP/PVC

Ugelli mod. P - T - R - D4.7
Nozzle mod. P - T - R - D4.7



Scheda tecnica a pag.
18 - 20 - 22 - 36
Data sheet pag.
18 - 20 - 22 - 36

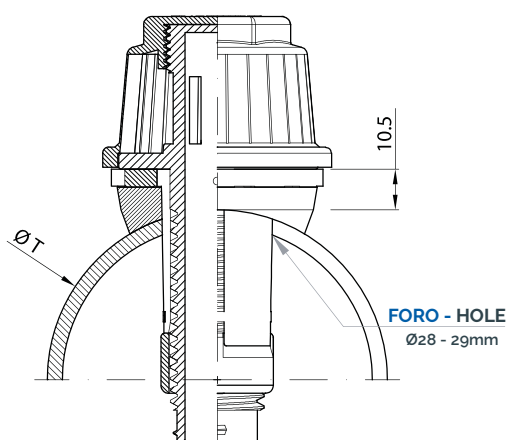

PTLT
PTL NOZZLE
+
TA ADAPTOR

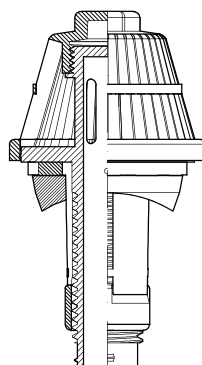

TTLT
TTL NOZZLE
+
TA ADAPTOR

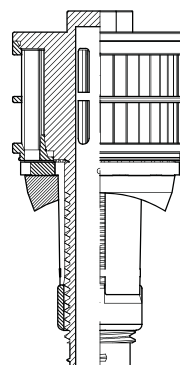

RTL
RTL NOZZLE
+
TA ADAPTOR

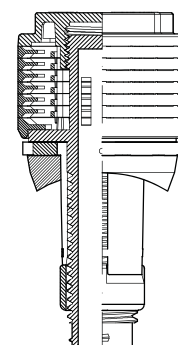

D4TL
D4TL NOZZLE
+
TA ADAPTOR

I fori del tubo dovranno essere smussati per evitare danni all'articolo.
The pipe holes must be chamfered to avoid item damage.



Code OD	Ø T - Diametro tubazione Pipe diameter range	Ø Foro tubo Pipe hole Ø mm	L2 - Lunghezza codolo Stem total length mm
63	60 - 63 mm	28.0 - 29.0	secondo esigenze del sistema according with system requirements
75	75 - 76 mm		
90	88 - 90 mm		
110	110 - 114 mm		
160	160 - 168 mm		

L'ufficio tecnico ILMAP è a disposizione per la configurazione del codolo ugello in base alle esigenze dei clienti.
ILMAP technical office is available for the configuration of the nozzle stem according to customer needs.