



- Adatti per la realizzazione di un sistema di drenaggio semplice ed economico rispetto alla piastra portaugelli
- Consente di ottenere una discreta uniformità di distribuzione
- Non adatto per la distribuzione di aria di controlavaggio

- Suitable for a simpler drain system, cheaper than nozzle plate
- It makes it possible to achieve a uniform distribution
- Not suitable for backwash with air distribution

Materiale

Material

Ugello - Nozzle

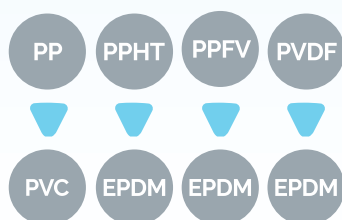

Adattatore - Adaptor

Modello Model	Fessura Slot width mm
PPT	0,25 - 0,50 - 0,80 - 1,00 - 2,00 - 3,00
TTT	0,25 - 0,40 - 0,50
RRT	0,20 - 0,25 - 0,30 - 0,35 - 0,50 - 0,60 - 1,00 - 2,00 - 3,00 - 5,00

ORDINE - ORDER			
Modello Model	Fessura Slot width	Ø T - Diametro tubazione Pipe diameter	Materiale Material
RRT	0,25	90	PP/PVC

Ugelli mod. P - T - R
Nozzle mod. P - T - R



Scheda tecnica
a pag. 18 - 20 - 22
Data sheet pag.
18 - 20 - 22

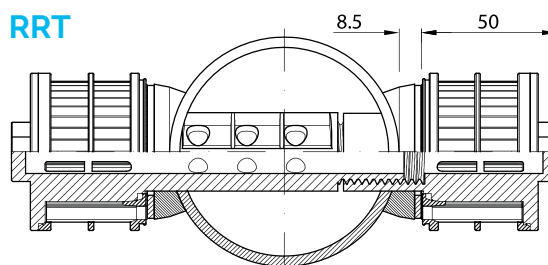
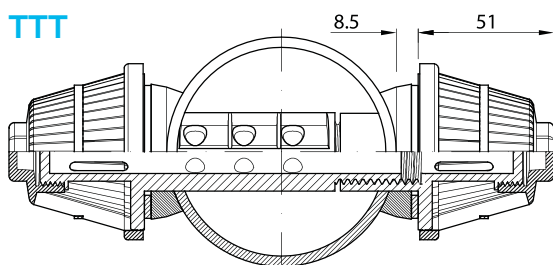
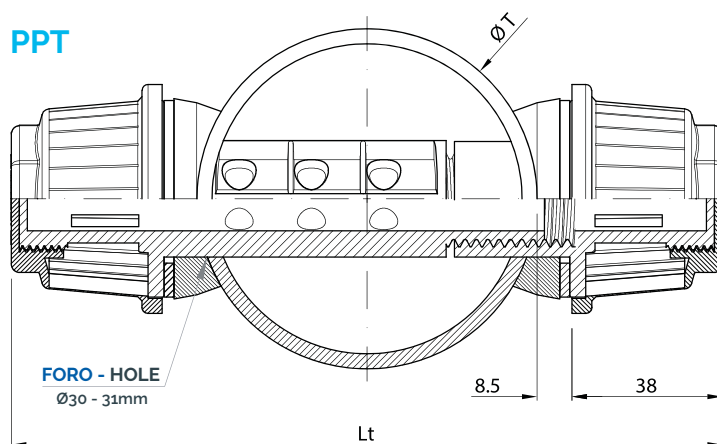

Code OD	Ø T - Diametro tubazione Pipe diameter range	Ø Foro tubo Pipe hole Ø mm	Lt		
			PPT	TTT	RRT
50	48 - 50 mm	30.0 - 31.0	143	169	167
63	60 - 63 mm		156	182	180
75	75 - 76 mm		168	194	192
90	88 - 90 mm		183	209	207
110	110 - 114 mm		203	229	227
160	160 - 168 mm		253	279	277

L'ufficio tecnico ILMAP è a disposizione per la configurazione del codolo ugello in base alle esigenze dei clienti.
ILMAP technical office is available for the configuration of the nozzle stem according to customer needs.