

# CSTo6

Collettori - 6 vie inclinate attacco superiore 2"G

Collectors - inclined 6 way upper thread 2"G



- Sistema di distribuzione e drenaggio economico per piccoli filtri con imboccatura superiore a 115mm
- Bracci inclinati per filtri a fondo bombato, per connessione dall'alto
- Inexpensive distribution and drain system for small filters with opening larger than 115mm
- Inclined lateral arms for filters with rounded heads, for upper connection

#### Materiale

Material

PP

PPHT

PPFV

PVDF

Modello Model	Montaggio bracci - SF/SFC - Arms assembly			Ø C Ø Coll assemblato Assembled coll Ø mm
	Fessura bracci Arms slot width	N° cupole Heads n°	Lt - Lunghezza bracci Lt - Arms length mm	
CSTo6	0,25 0,50	2	91	281
		3	128	351
		4	164	418
		5	201	488
		6	237	555
		7	274	625
		8	310	693
		9	347	762
		10	383	830
		11	420	899
		12	456	967
		13	493	1037
		14	529	1104
		15	566	1174
		16	602	1241
		...		602 + Lc

Collettore con certificazione ACS/MOCA prodotto PP Naturale (Bianco) - Collettore in PPFV30% prodotto Naturale (Avorio) - Collettore in PVDF prodotto Naturale (Bianco) - Collector with ACS/MOCA certification produced PP Natural (White) - Collector in PPFV30% produced Natural (Ivory) - Collector in PVDF produced Natural (White)

#### ORDINE - ORDER

Modello Model	Filetto Thread	Materiale Material
CSTo6	2"G	PP

Scheda tecnica  
a pag. 146  
Data sheet  
pag. 146

Bracci filtranti SF  
Filter arms SF

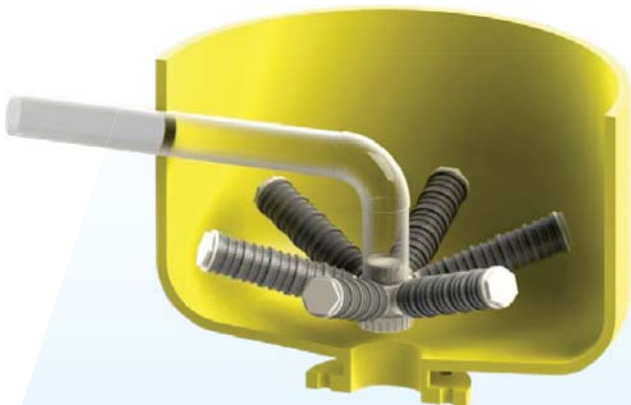
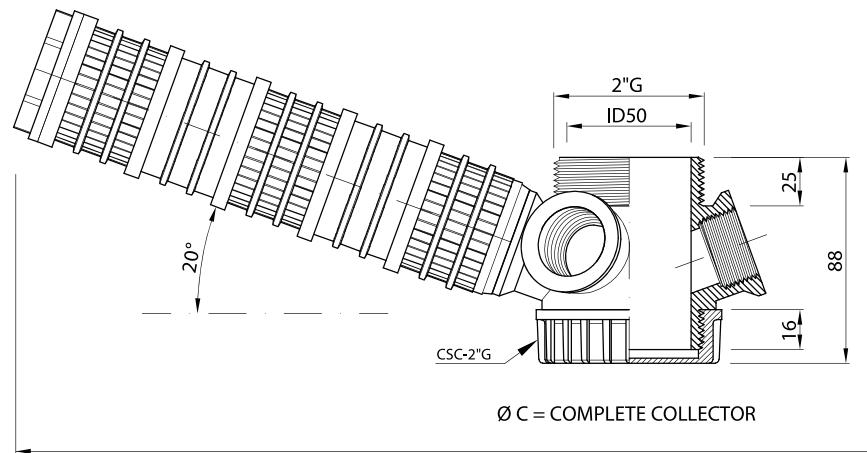
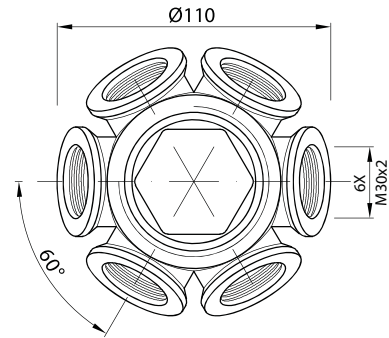
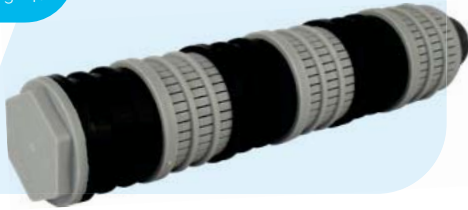

COLLECTOR CSTo6

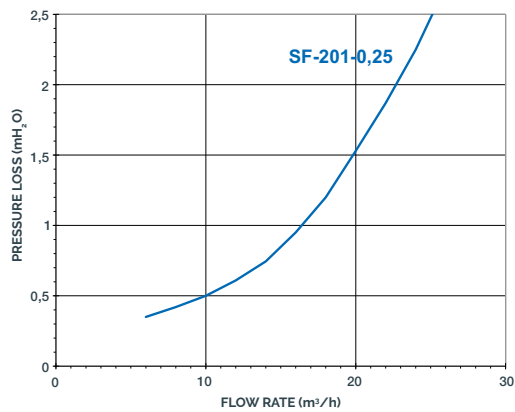

**NOTE**  
Su richiesta è possibile fornire la Curva di Perdita di Carico per tutta la gamma di ugelli Ilmap. The Pressure Loss Curve of the Ilmap Nozzles range can be supplied on demand.