



- Sistema di distribuzione e drenaggio economico per piccoli filtri con portate elevate
- Bracci inclinati per filtri a fondo bombato, per connessione dal basso
- Disponibile sia con filetto 3"G maschio (standard) che 3"G femmina
- Inexpensive distribution and drain system for small filters with high flow rate
- Inclined lateral arms for filters with rounded heads, for bottom connection
- Available with both 3 "G male (standard) and 3" G female threads

Materiale Material

PP

PPHT

PPFV

PVDF

Modello Model	Montaggio bracci - SF/SFC - Arms assembly			Ø C Ø Coll assemblato Assembled coll Ø mm	
	Fessura bracci Arms slot width	N° cupole Heads n°	Lt - Lunghezza bracci Lt - Arms length mm		
CS108	0,25 0,50	2	91	302	
		3	128	373	
		4	164	443	
		5	201	514	
		6	237	584	
		7	274	655	
		8	310	725	
		9	347	796	
		10	383	866	
		11	420	937	
		12	456	1007	
		13	493	1078	
		14	529	1148	
		15	566	1219	
		16	602	1289	
		...		602 + Lc	1289 + 70,5

Collettore con certificazione ACS/MOCA prodotto PP Naturale (Bianco) - Collettore in PPFV30% prodotto Naturale (Avorio) - Collettore in PVDF prodotto Naturale (Bianco) - Collector with ACS/MOCA certification produced PP Natural (White) - Collector in PPFV30% produced Natural (Ivory) - Collector in PVDF produced Natural (White)

ORDINE - ORDER

Modello Model	Filetto Thread	Materiale Material
CS108	3"G M	PP

Scheda tecnica
a pag. 146
Data sheet
pag. 146

Bracci filtranti SF
Filter arms SF

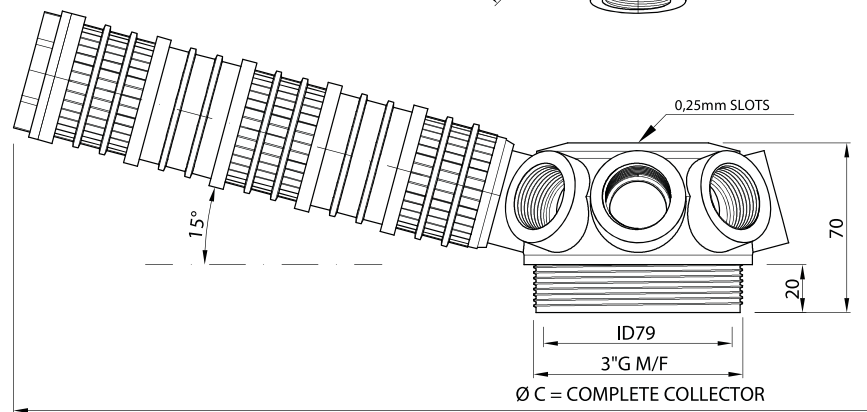
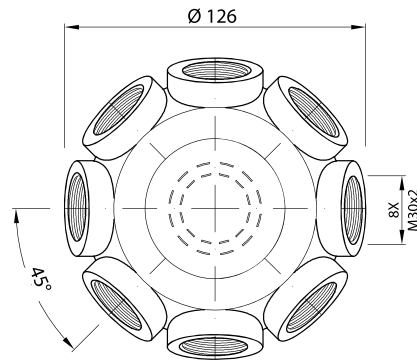
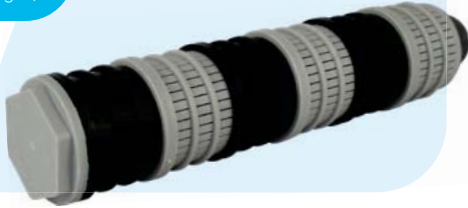

COLLECTOR CS108

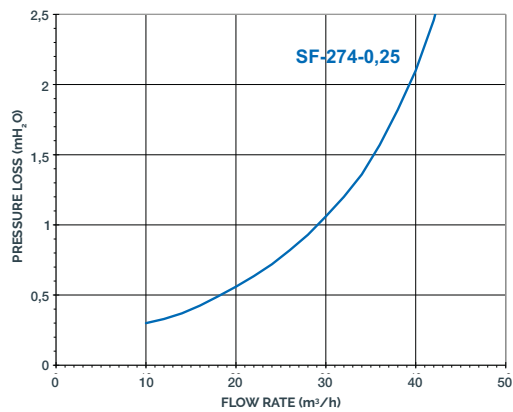

NOTE
Su richiesta è possibile fornire la Curva di Perdita di Carico per tutta la gamma di ugelli Ilmap. The Pressure Loss Curve of the Ilmap Nozzles range can be supplied on demand.