

# CS106 Collettori - 6 vie inclinate attacco inferiore 2"G

## Collectors - inclined 6 way lower thread 2"G



- Sistema di distribuzione e drenaggio economico per piccoli filtri con imboccatura superiore a 115mm
- Bracci inclinati per filtri a fondo bombato, per connessione dal basso
- Inexpensive distribution and drain system for small filters with opening larger than 115mm
- Inclined lateral arms for filters with rounded heads, for bottom connection

### Materiale

Material

PP

PPHT

PPFV

PVDF

Modello Model	Montaggio bracci - SF/SFC - Arms assembly			Ø C Ø Coll assemblato Assembled coll Ø mm	
	Fessura bracci Arms slot width	N° cupole Heads n°	Lt - Lunghezza bracci Lt - Arms length mm		
CS106	0,25 0,50	2	91	281	
		3	128	351	
		4	164	418	
		5	201	488	
		6	237	555	
		7	274	625	
		8	310	693	
		9	347	762	
		10	383	830	
		11	420	899	
		12	456	967	
		13	493	1037	
		14	529	1104	
		15	566	1174	
		16	602	1241	
		...		602 + Lc	1241 + 68,5

Collettore con certificazione ACS/MOCA prodotto PP Naturale (Bianco) - Collettore in PPFV30% prodotto Naturale (Avorio) - Collettore in PVDF prodotto Naturale (Bianco) - Collector with ACS/MOCA certification produced PP Natural (White) - Collector in PPFV30% produced Natural (Ivory) - Collector in PVDF produced Natural (White)

### ORDINE - ORDER

Modello  
Model  
CS106

Filetto  
Thread  
2"G

Materiale  
Material  
PP

Scheda tecnica  
a pag. 146  
Data sheet  
pag. 146

Bracci filtranti SF  
Filter arms SF

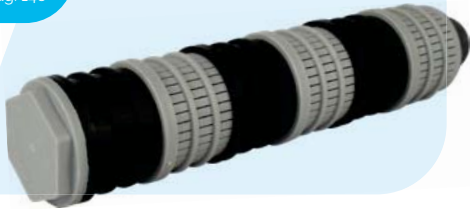

AC50

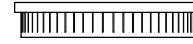

Anello fessurato AC50 non incluso  
Slot ring not included  
Fessura 0,20 mm - Slot 0,20 mm

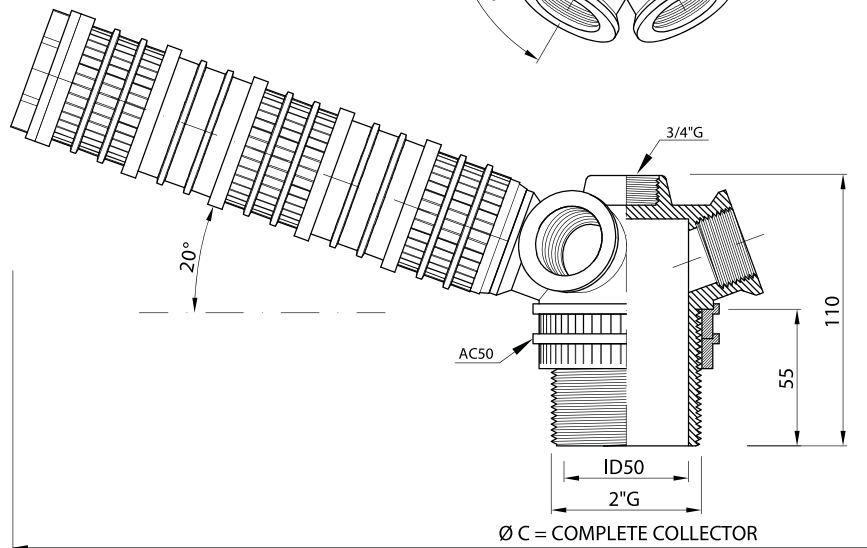
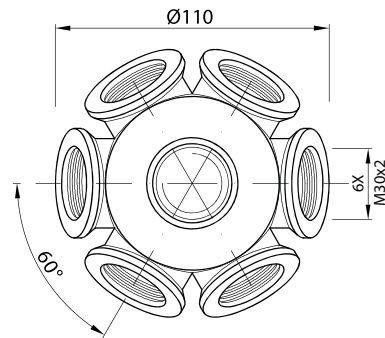

COLLECTOR CSI06

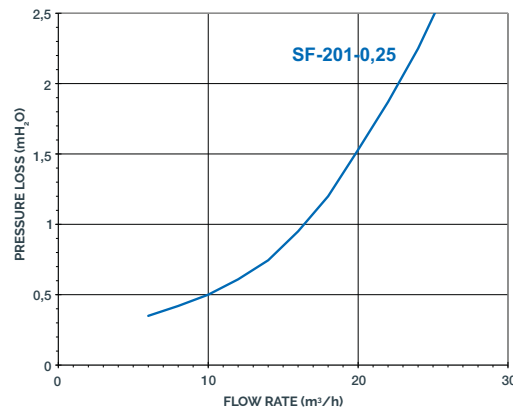

**NOTE**  
Su richiesta è possibile fornire la Curva di Perdita di Carico per tutta la gamma di ugelli Ilmap. The Pressure Loss Curve of the Ilmap Nozzles range can be supplied on demand.