

CSI05

Collettori - 5 vie inclinate attacco inferiore 2"G

Collectors - inclined 5 way lower thread 2"G



• Sistema di distribuzione e drenaggio economico per piccoli filtri con imboccatura stretta

• Inexpensive distribution and drain system for small filters with narrow opening

Materiale

Material

PP

PPHT

PPFV

PVDF

Modello Model	Montaggio bracci - SF/SFC - Arms assembly			Ø C Ø Coll assemblato Assembled coll Ø mm	
	Fessura bracci Arms slot width	N° cupole Heads n°	Lt - Lunghezza bracci Lt - Arms length mm		
CSI05	0,25 0,50	2	91	274	
		3	128	345	
		4	164	415	
		5	201	486	
		6	237	556	
		7	274	627	
		8	310	697	
		9	347	768	
		10	383	838	
		11	420	909	
		12	456	979	
		13	493	1050	
		14	529	1120	
		15	566	1191	
		16	602	1261	
		...		602 + Lc	1261 + 70,5

Collettore con certificazione ACS/MOCA prodotto PP Naturale (Bianco) - Collettore in PPFV30% prodotto Naturale (Avorio) - Collettore in PVDF prodotto Naturale (Bianco) - Collector with ACS/MOCA certification produced PP Natural (White) - Collector in PPFV30% produced Natural (Ivory) - Collector in PVDF produced Natural (White)

ORDINE - ORDER

Modello Model	Filetto Thread	Materiale Material
CSI05	2"G	PP

Scheda tecnica
a pag. 146
Data sheet
pag. 146

Bracci filtranti SF
Filter arms SF

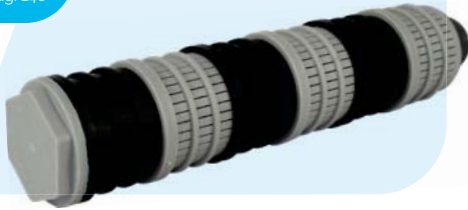

AC50

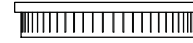

Anello fessurato AC50 non incluso
Slot ring not included
Fessura 0,20 mm - Slot 0,20 mm

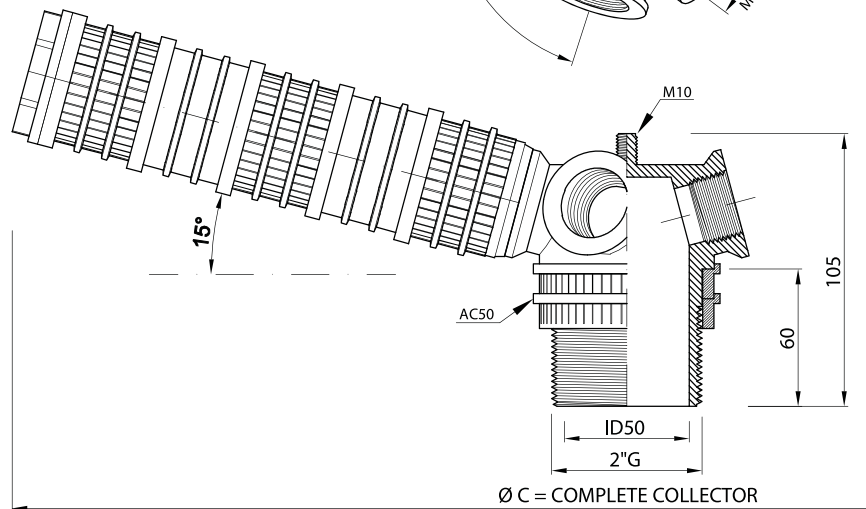
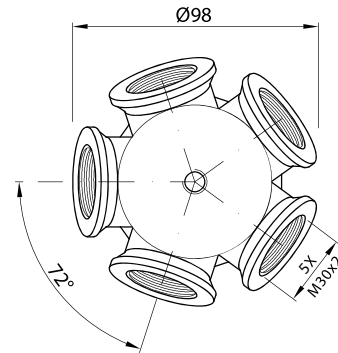

COLLECTOR CSI05

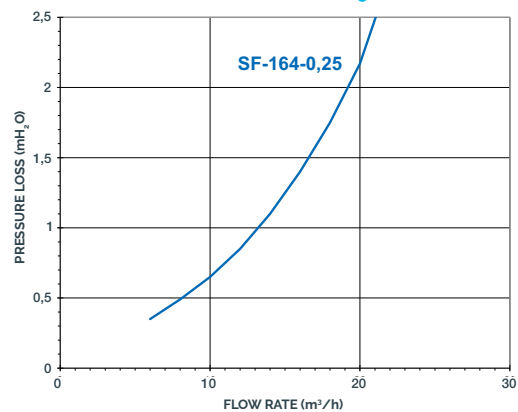

NOTE
Su richiesta
è possibile
fornire la Curva
di Perdita di
Carico per tut-
ta la gamma di
ugelli Ilmap.
The Pressure
Loss Curve of
the Ilmap Noz-
zles range can
be supplied on
demand.