

# CSD08

Collettori - 8 vie inclinate attacco superiore 3"G  
Collectors - inclined 8 way upper thread 3"G



- Sistema di distribuzione e drenaggio economico per piccoli filtri con portate elevate
- Bracci inclinati per filtri a fondo bombato, per connessione dal basso
- Disponibile sia con filetto 3"G maschio (standard) che 3"G femmina

- Inexpensive distribution and drain system for small filters with high flow rate
- Inclined lateral arms for filters with rounded heads, for lower connection
- Available with both 3 "G male (standard) and 3" G female threads

**Materiale**  
Material

PP

PPHT

PPFV

PVDF

Modello Model	Montaggio bracci - SF/SFC - Arms assembly			Ø C Ø Coll assemblato Assembled coll Ø mm
	Fessura bracci Arms slot width	N° cupole Heads n°	Lt - Lunghezza bracci Lt - Arms length mm	
CSD08	0,25 0,50	2	91	302
		3	128	373
		4	164	443
		5	201	514
		6	237	584
		7	274	655
		8	310	725
		9	347	796
		10	383	866
		11	420	937
		12	456	1007
		13	493	1078
		14	529	1148
		15	566	1219
		16	602	1289
		...		602 + Lc

Collettore con certificazione ACS/MOCA prodotto PP Naturale (Bianco) - Collettore in PPFV30% prodotto Naturale (Avorio) - Collettore in PVDF prodotto Naturale (Bianco) - Collector with ACS/MOCA certification produced PP Natural (White) - Collector in PPFV30% produced Natural (Ivory) - Collector in PVDF produced Natural (White)

## ORDINE - ORDER

Modello  
Model  
CSD08

Filetto  
Thread  
3"G M

Materiale  
Material  
PP

Scheda tecnica  
a pag. 146  
Data sheet  
pag. 146

Bracci filtranti SF  
Filter arms SF

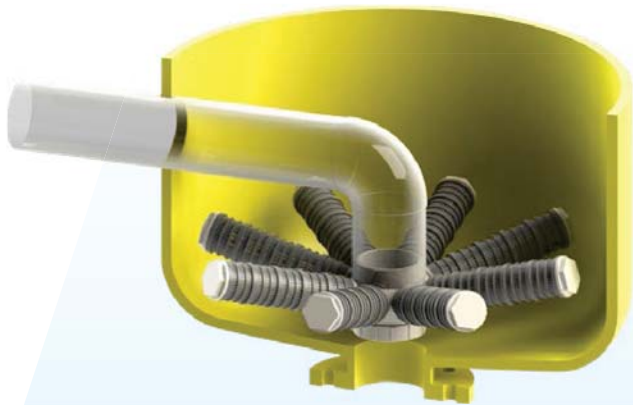
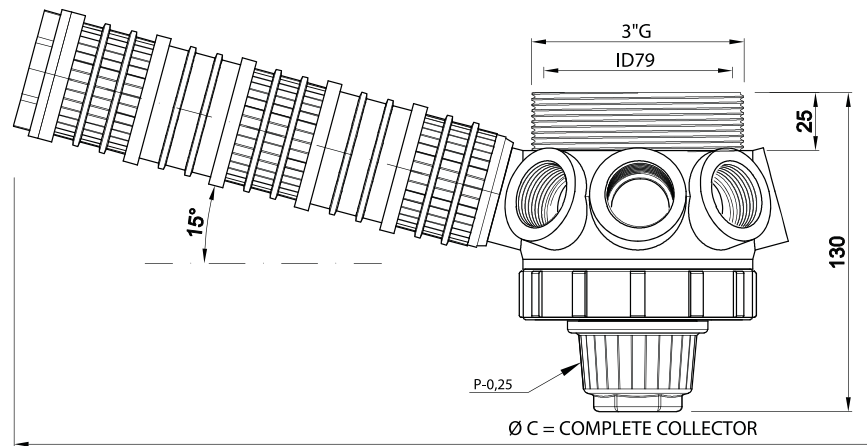
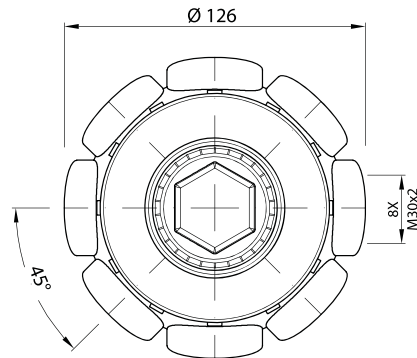
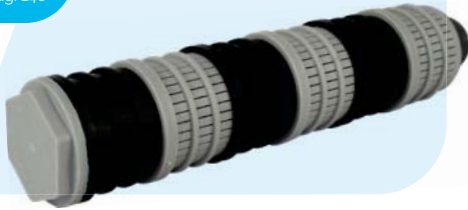

COLLECTOR CSD08

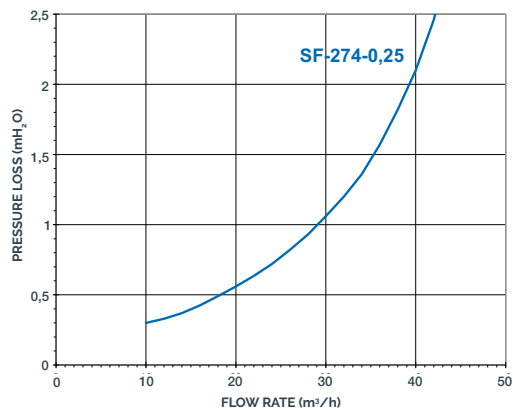

**NOTE**  
Su richiesta è possibile fornire la Curva di Perdita di Carico per tutta la gamma di ugelli Ilmap. The Pressure Loss Curve of the Ilmap Nozzles range can be supplied on demand.