



- Sistema di distribuzione e drenaggio economico per piccoli filtri con imboccatura superiore a 115mm
- Bracci dritti per connessione dall'alto e dal basso

- Inexpensive distribution and drain system for small filters with opening larger than 115mm
- Straight lateral arms for upper and lower connection

**Materiale**  
Material

PP

PPHT

PPFV

PVDF

Modello Model	Montaggio bracci - SF/SFC - Arms assembly			Ø C Ø Coll assemblato Assembled coll Ø mm
	Fessura bracci Arms slot width	N° cupole Heads n°	Lt - Lunghezza bracci Lt - Arms length mm	
CST06	0,25 0,50	2	91	277
		3	128	351
		4	164	423
		5	201	497
		6	237	569
		7	274	643
		8	310	715
		9	347	789
		10	383	861
		11	420	935
		12	456	1007
		13	493	1081
		14	529	1153
		15	566	1227
		16	602	1299
		...		602 + Lc

Collettore con certificazione ACS/MOCA prodotto PP Naturale (Bianco) - Collettore in PPFV30% prodotto Naturale (Avorio) - Collettore in PVDF prodotto Naturale (Bianco) - Collector with ACS/MOCA certification produced PP Natural (White) - Collector in PPFV30% produced Natural (Ivory) - Collector in PVDF produced Natural (White)

### ORDINE - ORDER

Modello  
Model  
CSD06

Filetto  
Thread  
2"G

Materiale  
Material  
PP

Scheda tecnica  
a pag. 146  
Data sheet  
pag. 146

Bracci filtranti SF  
Filter arms SF

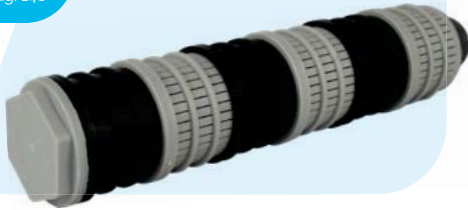

AC50

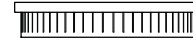

Anello fessurato AC50 non incluso  
Slot ring not included  
Fessura 0,20 mm - Slot 0,20 mm

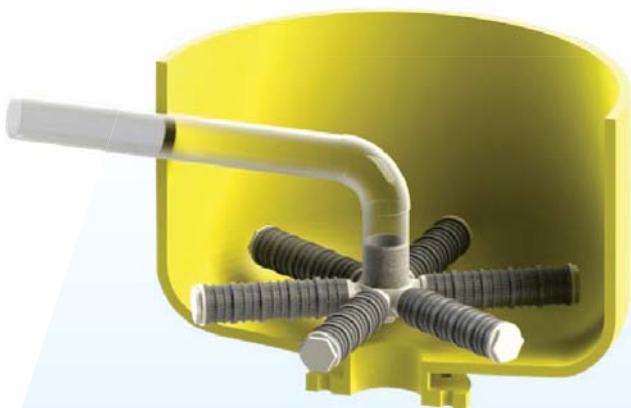
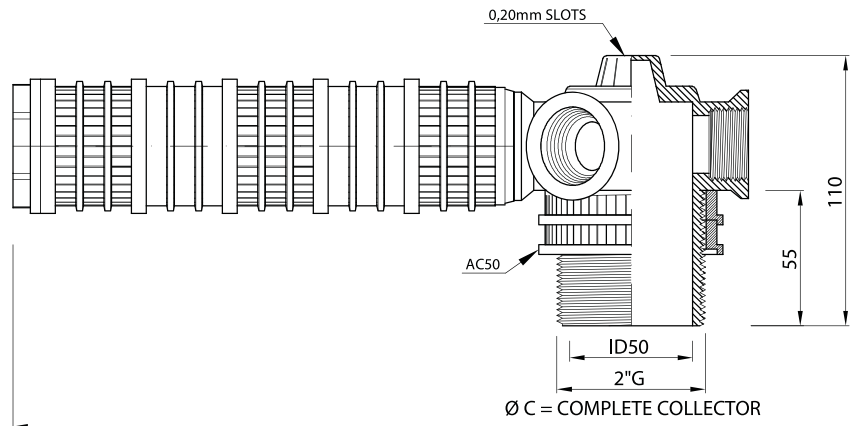
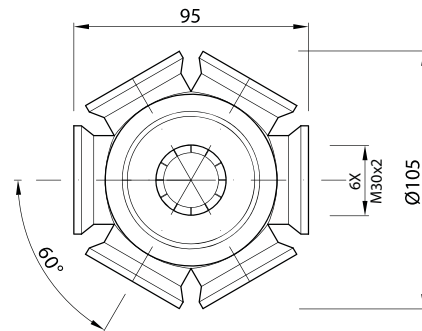

COLLECTOR CSD06

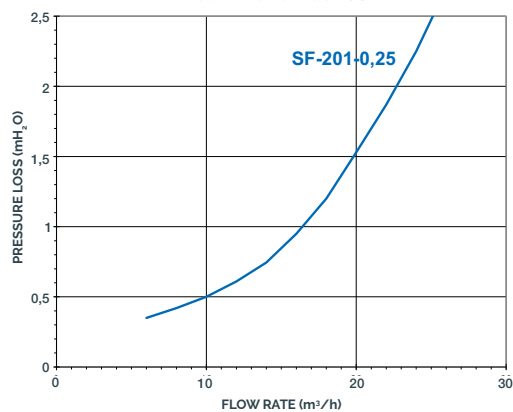

**NOTE**  
Su richiesta  
è possibile  
fornire la Curva  
di Perdita di  
Carico per tut-  
ta la gamma di  
ugelli Ilmap.  
The Pressure  
Loss Curve of  
the Ilmap Noz-  
zles range can  
be supplied on  
demand.