

AM-AS

Ugelli sottovalvola per addolcitori

Upper filter nozzles for softeners



- Ampia superficie filtrante e basse perdite di carico
- Attacco a baionetta o filettato
- High filtering area and low pressure loss
- Bayonet or threaded connection

Materiale
Material

ABS

Modello Model	ID - Diametro tubazione ID - Pipe diameter mm		Fessura Slot width mm	Area mm ²	Connessione Connection
AMB21	21	13/16"	0,25	396	Baionetta Bayonet
AMB27	27	1,05"			
AMF21	21	13/16"			Filettato Threaded
AMF27	27	1,05"			
ASB21	21	13/16"	0,25	720	Baionetta Bayonet
ASB27	27	1,05"			
ASB32	32				
ASF21	21	13/16"			Filettato Threaded
ASF27	27	1,05"			
ASF32	32				

Ugello prodotto in ABS Naturale (Bianco) - Nozzle produced in ABS Natural (White)

ORDINE - ORDER

Modello Model	Fessura Slot width	Materiale Material
ASB32	0,25	ABS

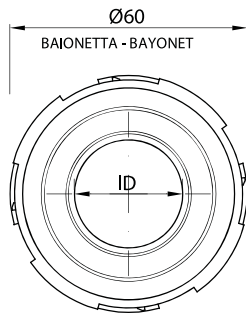

AMB

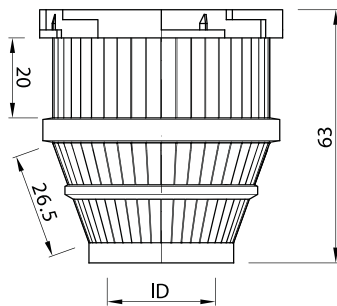

ASB

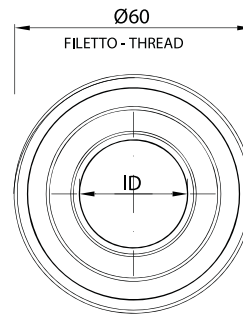
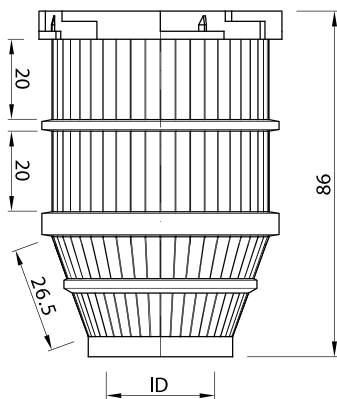

AMF

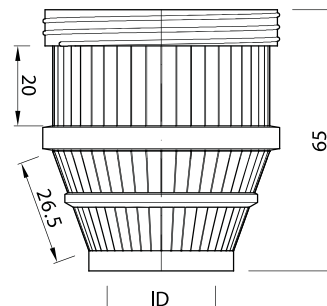

ASF

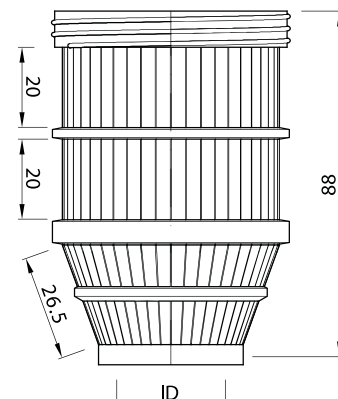

NOZZLE AM - AS

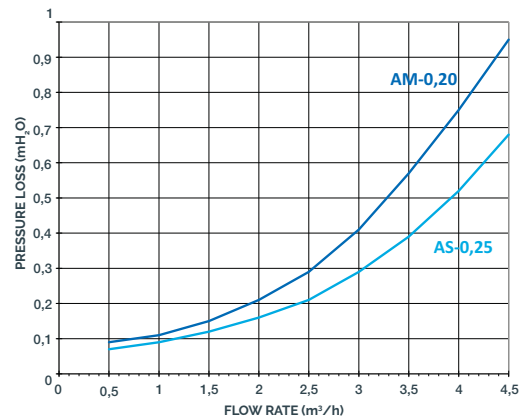

NOTE

Su richiesta è possibile fornire la Curva di Perdita di Carico per tutta la gamma di ugelli Ilmap. The Pressure Loss Curve of the Ilmap Nozzles range can be supplied on demand.