



# FLAT FAN NOZZLES



## CORRECT OVERLAPPING

When several nozzles are used to spray, it's very important to produce a uniform spray distribution. The correct sprays overlapping methods are shown here below.

### STANDARD CONVEX DISTRIBUTION

In a standard convex spray distribution the medium section has a larger capacity than the two lateral sections. It's necessary to overlap 50% of the spray range.

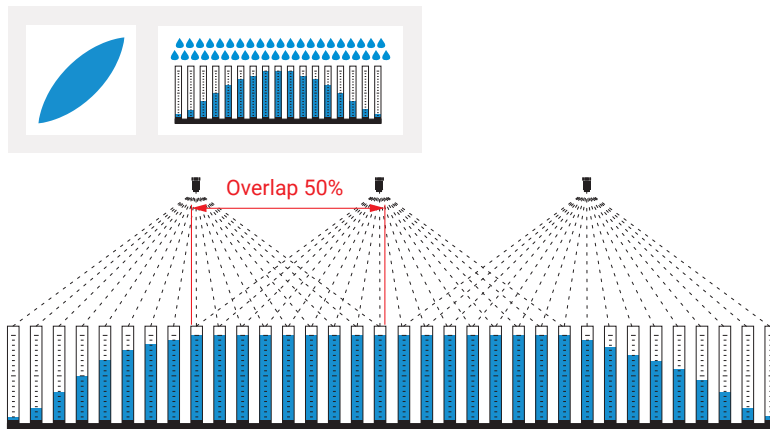

### STANDARD EVEN DISTRIBUTION

An equal distribution provides a uniform spray and 10% of the spray range overlaps.

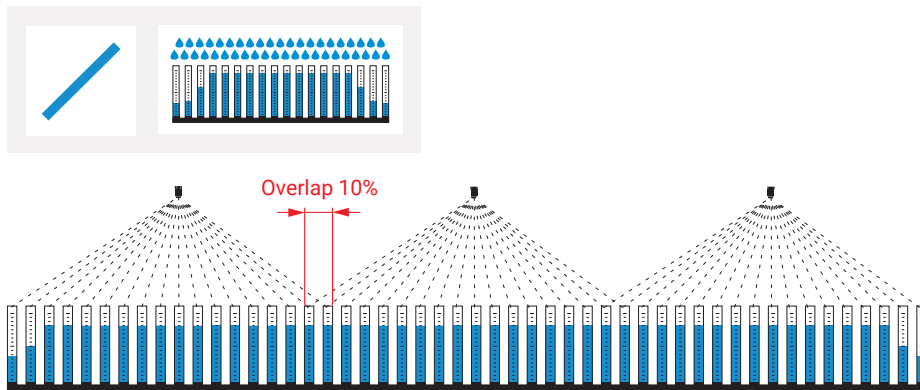

### OFFSET

A flat fan nozzle produces a high impact jet with a 5°-15° offset angle to avoid overlapping and interference. The offset angle depends on the spray range of the flat fan nozzle.

SPRAY ANGLE	OFFSET ( $\alpha$ )
15°~60°	5°~10°
60°~120°	10°~15°

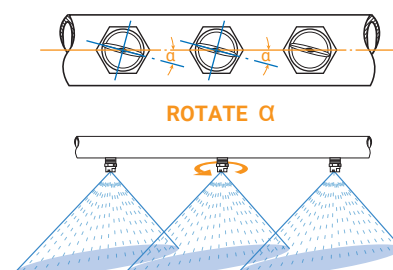

### FLAT FAN NOZZLES LOW PRESSURE, WIDE ANGLE

K series nozzles work on the principle of jet deflection, conveying the liquid against an accurately machined sloping surface to change the flow direction and produce a fan-shaped mist with a 75° spray angle. Medium-sized droplets and medium/low impact values.

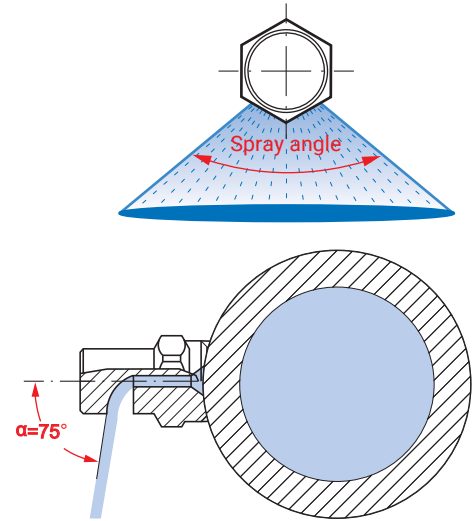

### FLAT FAN NOZZLES HIGH IMPACT

K nozzles high-impact type work on the principle of jet deflection. The liquid flow is conveyed onto a deflection sloping surface specially designed to produce a high impact narrow flat fan and medium-sized droplets. They are widely used in operating environments requiring high impact spray jets. Moreover, their rounded orifice and free inside passage minimize the risk of clogging. There is a specific angle that must be kept to ensure spray direction (see below picture ~ CL).

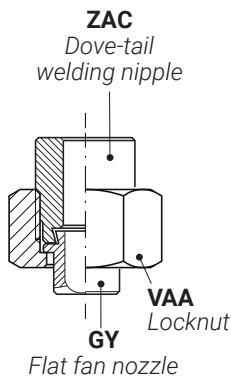
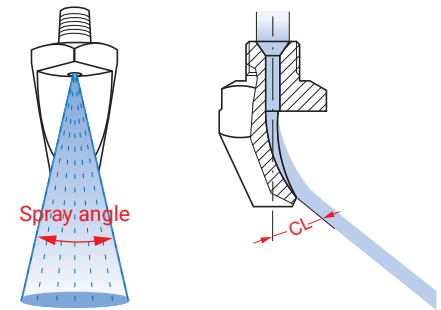

### DOVE-TAIL FLAT FAN NOZZLE

Flat fan nozzle tips provide a high impact spray. Adjacent nozzles must rotate with a specific offset angle to avoid interference and produce a uniform spray coverage when their jets overlap. For the GY series nozzle tips an offset angle  $\sim \alpha$  must be set between the spray plane and their dovetail guide. Their specific dove-tail design ensures the correct spray direction and allows time saving as spray angles must not be adjusted each time. For thread size 3/8" offset angle is 5°. For thread size 3/4" offset angle is 15°. The picture to the right shows an offset angle  $\sim \alpha$  between the spray plane and the dovetail.

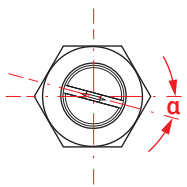
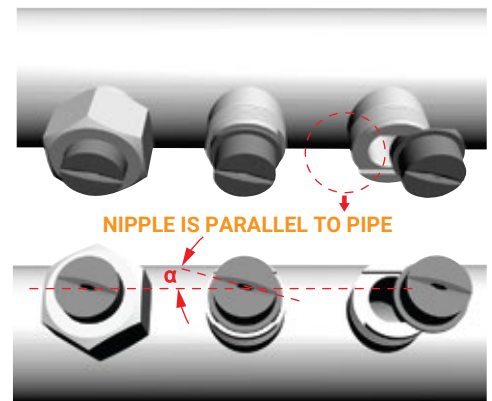

### EQUIVALENT NOZZLE TIP DIAMETER

Flat fan nozzles produce cat-eye shaped or parabolic distribution patterns with different capacities. Hence nozzle tips have long and short side differences. For convenience reasons, their "cat-eye shaped" spray pattern is converted into the area of a circle. The datum so obtained from the conversion is called "equivalent nozzle tip diameter".

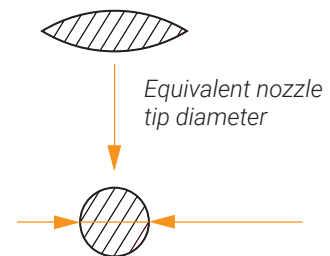

**CAT-EYE**  
STANDARD CONVEX DISTRIBUTION

**RECTANGLE**  
EVEN DISTRIBUTION

### FLANGED NOZZLE

Flanged nozzles have no thread. The nozzle tip is installed on a welding nipple and fastened with a locknut.

The scope of their design is:

1. Easy adjustment of the spray direction
2. Easy maintenance

The diagram below shows the possible mounting combinations:



### CLAMP / NIPPLE + FILTER + NOZZLE + LOCKNUT

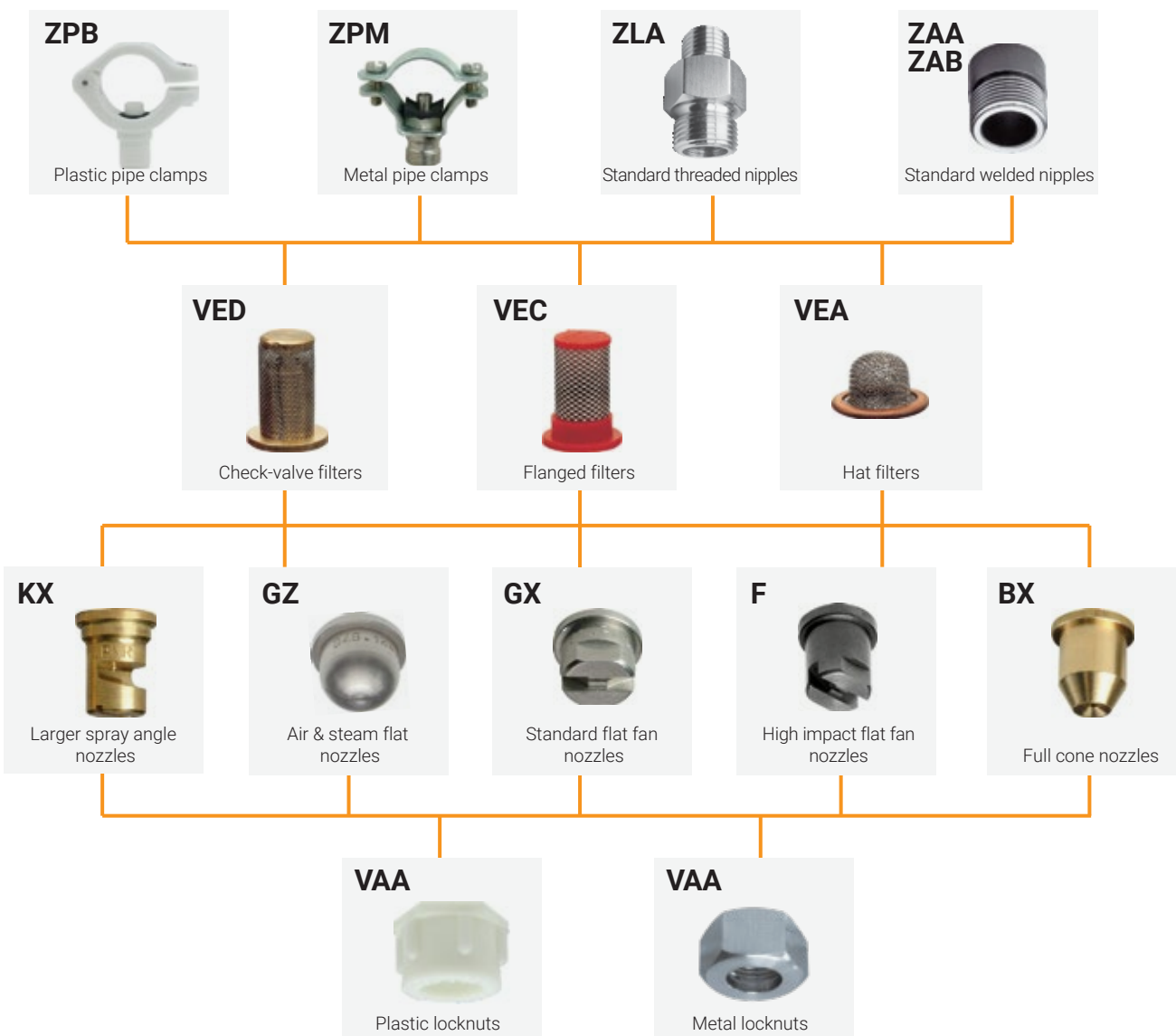
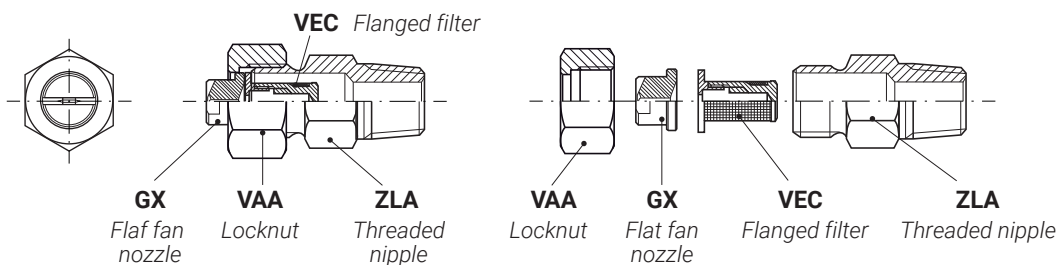

# F ( FLAT FAN NOZZLES / HIGH PRESSURE WASHING )



## HIGH PRESSURE WASHING

Flat fan nozzles F series are designed for high-pressure washing applications. Their specially designed inner profile allows for even jet distribution, which results in effective and uniform cleaning action over the surface being processed. All nozzles are precisely machined and made of hardened stainless steel AISI 416.

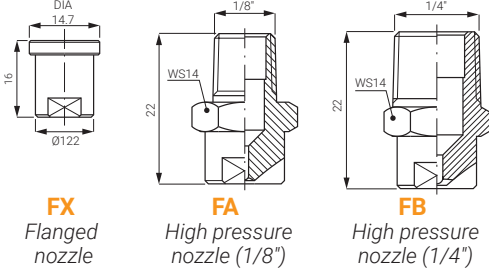

THREAD SPECIFICATION: BSPT, NPT  
 TYPICAL APPLICATIONS  
 Car washing  
 High pressure washers  
 Industrial cleaning

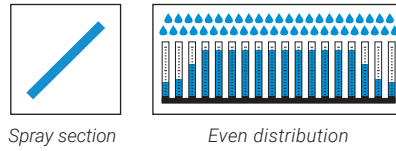

Nozzle type	Thread size
FA - FG	1/8" BSPT - NPT
FB - FH	1/4" BSPT - NPT
FX	Ø14.7

0°		15°			25°			40°			65°			US GALS	PNR CODE	Capacity at different pressure values (l/min) (bar)							
FAA	FBA	FXA	FAB	FBB	FXB	FAD	FBD	FXD	FAL	FBL	FXL	FAR	FBR			FXR	20	30	50	70	100	150	200
•	•	•	•	•	•	•	•	•	•	•	•	•	•	•	015	1340	1.52	1.86	2.40	2.84	3.40	4.16	4.81
•	•	•	•	•	•	•	•	•	•	•	•	•	•	•	02	1460	2.06	2.52	3.25	3.85	4.60	5.63	6.51
•	•	•	•	•	•	•	•	•	•	•	•	•	•	•	025	1560	2.50	3.07	3.96	4.69	5.60	6.86	7.92
•	•	•	•	•	•	•	•	•	•	•	•	•	•	•	03	1686	3.07	3.76	4.85	5.74	6.86	8.40	9.70
•	•	•	•	•	•	•	•	•	•	•	•	•	•	•	035	1812	3.63	4.45	5.74	6.79	8.12	9.94	11.5
•	•	•	•	•	•	•	•	•	•	•	•	•	•	•	04	1930	4.16	5.09	6.58	7.78	9.30	11.4	13.2
•	•	•	•	•	•	•	•	•	•	•	•	•	•	•	045	2103	4.61	5.64	7.28	8.62	10.3	12.6	14.6
•	•	•	•	•	•	•	•	•	•	•	•	•	•	•	05	2116	5.19	6.35	8.20	9.71	11.6	14.2	16.4
•	•	•	•	•	•	•	•	•	•	•	•	•	•	•	055	2126	5.63	6.90	8.91	10.5	12.6	15.4	17.8
•	•	•	•	•	•	•	•	•	•	•	•	•	•	•	06	2138	6.17	7.56	9.76	11.5	13.8	16.9	19.5
•	•	•	•	•	•	•	•	•	•	•	•	•	•	•	065	2149	6.66	8.16	10.5	12.5	14.9	18.2	21.1
•	•	•	•	•	•	•	•	•	•	•	•	•	•	•	07	2160	7.16	8.76	11.3	13.4	16.0	19.6	22.6
•	•	•	•	•	•	•	•	•	•	•	•	•	•	•	075	2170	7.60	9.31	12.0	14.2	17.0	20.8	24.0
•	•	•	•	•	•	•	•	•	•	•	•	•	•	•	08	2181	8.09	9.91	12.8	15.1	18.1	22.2	25.6
•	•	•	•	•	•	•	•	•	•	•	•	•	•	•	085	2192	8.59	10.5	13.6	16.1	19.2	23.5	27.2
•	•	•	•	•	•	•	•	•	•	•	•	•	•	•	09	2204	9.12	11.2	14.4	17.1	20.4	25.0	28.8
•	•	•	•	•	•	•	•	•	•	•	•	•	•	•	095	2226	10.1	12.4	16.0	18.9	22.6	27.7	32.0
•	•	•	•	•	•	•	•	•	•	•	•	•	•	•	10	2230	10.3	12.6	16.3	19.2	23.0	28.2	32.5
•	•	•	•	•	•	•	•	•	•	•	•	•	•	•	11	2248	11.1	13.6	17.5	20.7	24.8	30.4	35.1
•	•	•	•	•	•	•	•	•	•	•	•	•	•	•	12	2272	12.2	14.9	19.2	22.8	27.2	33.3	38.5
•	•	•	•	•	•	•	•	•	•	•	•	•	•	•	12.5	2280	12.5	15.3	19.8	23.4	28.0	34.3	39.6
•	•	•	•	•	•	•	•	•	•	•	•	•	•	•	13	2296	13.2	16.2	20.9	24.8	29.6	36.3	41.9
•	•	•	•	•	•	•	•	•	•	•	•	•	•	•	14	2320	14.3	17.5	22.6	26.8	32.0	39.2	45.3
•	•	•	•	•	•	•	•	•	•	•	•	•	•	•	15	2341	15.2	18.7	24.1	28.5	34.1	41.8	48.2
•	•	•	•	•	•	•	•	•	•	•	•	•	•	•	16	2360	16.1	19.7	25.5	30.1	36.0	44.1	50.9
•	•	•	•	•	•	•	•	•	•	•	•	•	•	•	18	2410	18.3	22.5	29.0	34.3	41.0	50.2	58.0
•	•	•	•	•	•	•	•	•	•	•	•	•	•	•	20	2456	20.4	25.0	32.2	38.2	45.6	55.8	64.5
•	•	•	•	•	•	•	•	•	•	•	•	•	•	•	25	2567	25.4	31.1	40.1	47.4	56.7	69.4	80.2
•	•	•	•	•	•	•	•	•	•	•	•	•	•	•	30	2682	30.5	37.4	48.2	57.1	68.2	83.5	96.4
•	•	•	•	•	•	•	•	•	•	•	•	•	•	•	35	2800	35.8	43.8	56.6	66.9	80.0	98.0	113
•	•	•	•	•	•	•	•	•	•	•	•	•	•	•	40	2910	40.7	49.8	64.3	76.1	91.0	111	128
•	•	•	•	•	•	•	•	•	•	•	•	•	•	•	50	3113	50.5	61.9	79.9	94.5	113	138	160
•	•	•	•	•	•	•	•	•	•	•	•	•	•	•	60	3135	60.4	73.9	95.5	113	135	165	191

HOW TO MAKE UP THE NOZZLE CODE

Ex.: FAA 1340 C2

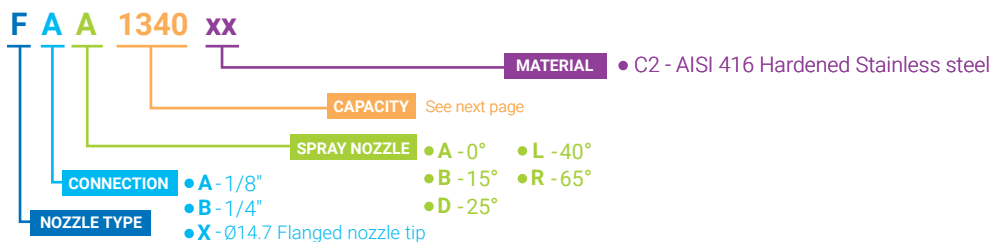

# ( FLAT FAN NOZZLES / HIGH PRESSURE WASHING ) F

OUTER DIMENSION OF F TYPE NOZZLES AND FX NOZZLE TIPS (CODE)

The table on the right shows the correspondence between the nominal capacity in US Gallons per minute at 40 psi, which is commonly used to identify high pressure washing nozzles and the PNR capacity code at 100 bar. For the convenience of worldwide use, all nozzles are US coding system.

For example:

**FBA 1686 C2** (PNR code) nozzle will be codified as **00/03** (US Gallons) with a spray angle 0° and capacity 0.3 Gals/min at a pressure of 40 psi.

**FBD 2116 C2** (PNR code) nozzle will be codified as **25/05** (US Gallons) with a spray angle 25° and capacity 0.5 Gals/min at a pressure of 40 psi. (see below)

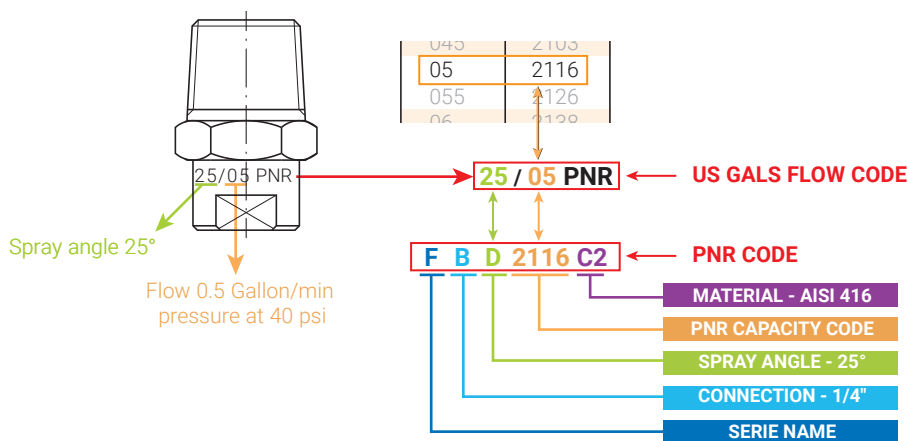

US GALLONS	PNR CODE
015	1340
02	1460
025	1560
03	1686
035	1812
04	1930
045	2103
05	2116
055	2126
06	2138
065	2149
07	2160
075	2170
08	2181
085	2192
09	2204
095	2220
10	2230
11	2248
12	2272
12.5	2280
13	2296
14	2320
15	2341
16	2360
18	2410
20	2456
25	2567
30	2682
35	2800
40	2910
50	3113
60	3135

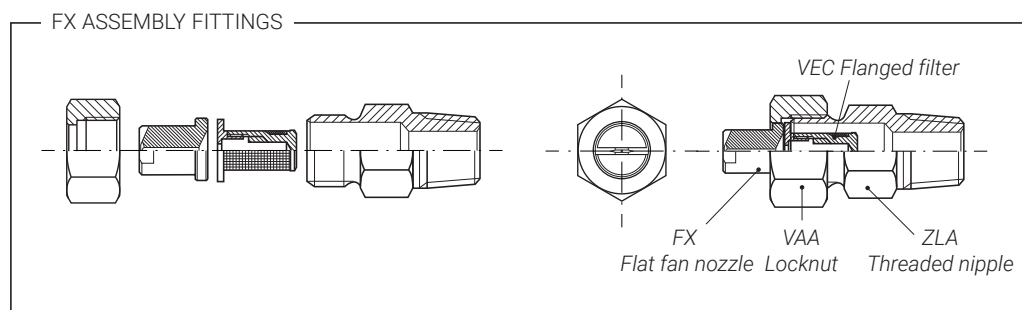

## HIGH PRESSURE WASHING ACCESSORIES

We have all kinds of washing guns (low/medium/high/superhigh pressure) and accessories for various washing applications and environments. We will help you to chose the best solution for your needs.



**UMW 0010 D4**  
High pressure gun  
P. 97



**UMW 0020 D4**  
High pressure gun  
P. 97



**UMW 0030 B3**  
High pressure lance  
P. 98



**UMW 0045 B3**  
High pressure lance  
P. 98



**UMU J/I**  
Auto-rewind reelst  
P. 102

## OPTIONAL ELEMENT- FLOW STRAIGHTENER

Flow straighteners improve spray jet efficiency by straightening the liquid path to minimize turbulence and produce swirl-free, even, stable and straight-run flows. All PNR nozzles are ready to embed a flow straightener. These items can be supplied separately on request.



# GA (FLAT FAN NOZZLES / SHORT BODY)

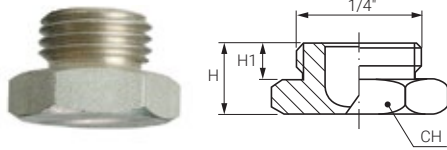

1/4" Standard Capacity

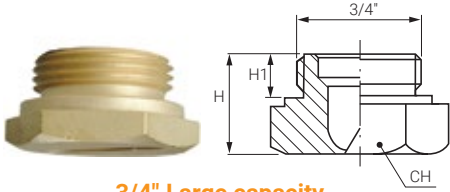

3/4" Large capacity

## SHORT BODY

The special short body design of the GA nozzles makes it possible to use nozzle spray pipes in such machines or systems where the available space is very limited. (for ex., tight turns in traps and elbows).

They allow an even jet distribution and a proper force of impact. GA nozzles are available in two types: 1/4" standard capacity and 3/4" large capacity. They are made in brass, stainless steel or in plastic materials to suit different working environments. GA nozzles in plastic materials are made with a longer thread and bigger front for higher efficiency and longer service life.

THREAD SPECIFICATION: BSP



Spray section

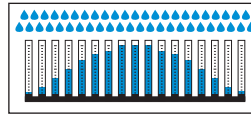

Convex distribution



### TYPICAL APPLICATIONS

#### Washing:

Filter cleaning in paper making machines and dryers

#### Cooling:

Continuous casting  
Product cooling

#### Other applications:

Spray of chemicals  
Water curtains for toxic gases suppression  
Excellent for pipe, sewer and drain cleaning

CAPACITY CODE	Capacity at different pressure values									(l/min) (bar)
	0.5	1.0	1.5	2.0	3.0	4.0	5.0	7.0	10	
BSP 1/4" THREADED	0780*	0,32	0,45	0,55	0,64	0,78	0,9	1,01	1,19	1,42
	1124	0,51	0,72	0,88	1,01	1,24	1,43	1,6	1,89	2,27
	1160	0,65	0,92	1,13	1,31	1,6	1,85	2,07	2,44	2,92
	1190	0,78	1,1	1,34	1,55	1,9	2,19	2,45	2,9	3,47
	1233	0,95	1,35	1,65	1,9	2,33	2,69	3,01	3,56	4,25
	1244	1	1,41	1,73	1,99	2,44	2,82	3,15	3,73	4,45
	1310	1,27	1,79	2,19	2,53	3,1	3,58	4	4,74	5,66
	1385	1,57	2,22	2,72	3,14	3,85	4,45	4,97	5,88	7,03
	1490	2	2,83	3,46	4	4,9	5,66	6,33	7,48	8,95
	1581	2,37	3,35	4,11	4,74	5,81	6,71	7,5	8,87	10,61
	1780	3,18	4,5	5,52	6,37	7,8	9,01	10,07	11,91	14,24
	1980	4	5,66	6,93	8	9,8	11,32	12,65	14,97	17,89
	2124	5,1	7,2	8,8	10,1	12,4	14,3	16	18,9	22,6
	2153	6,2	8,8	10,8	12,5	15,3	17,7	19,8	23,4	27,9
2194	7,9	11,2	13,7	15,8	19,4	22,4	25	29,6	35,4	
2245	10	14,1	17,3	20	24,5	28,3	31,6	37,4	44,7	

\* Not available in B31, D2 and E1.

CAPACITY CODE	Capacity at different pressure values									(l/min) (bar)
	0.5	1.0	1.5	2.0	3.0	4.0	5.0	7.0	10	
BSP 3/4" THREADED	2154	6,2	8,8	10,8	12,5	15,3	17,7	19,8	23,4	27,9
	2195	7,9	11,2	13,7	15,8	19,4	22,4	25	29,6	35,4
	2246	10	14,1	17,3	20	24,5	28,3	31,6	37,4	44,7
	2311	12,7	18	22	25,4	31,1	35,9	40,1	47,5	56,8
	2490	20	28,3	34,6	40	49	56,6	63,3	74,8	89,5
	2610	24,9	35,2	43,1	49,8	61	70,4	78,8	93,2	111,4
	2760	31	43,9	53,7	62,1	76	87,8	98,1	116,1	138,8
	2930	38	53,7	65,8	75,9	93	107,4	120,1	142,1	169,8
	3122	49,8	70,4	86,3	99,6	122	140,9	157,5	186,4	222,7

Longer thread and bigger front design for short-body nozzles in plastic to ensure safer operating performances and longer service life.



Material	Dimensions (mm)					
	Small size (1/4")			Large size (3/4")		
	H	H1	CH	H	H1	CH
B1 - AISI 303 SS	12	7	17	15	8	32
B31 - AISI 316L SS						
T1 - Brass	17	7	17	23	11	32
D2 - PP						
E1 - PTFE						
D1 - PVC						

### HOW TO MAKE UP THE NOZZLE CODE

EX.: GAM 1490 B1

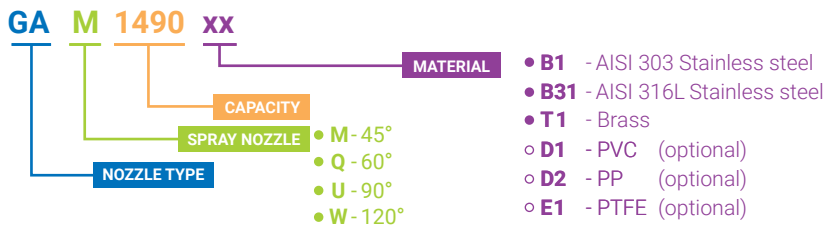



( FLAT FAN NOZZLE TIPS ) **GX**

LOW CAPACITY

Flat fan nozzle tips are usually mounted onto a pipe by means of a welded nipple or a clamp, and secured in place with a retaining nut. They can be easily replaced and the jet can be conveniently oriented in the desired direction.

The tips models shown on this page delivery very low flow values. Their precisely machined small orifices can be protected from clogging by means of a filter assembled inside our nipples and clamps that are designed for this purpose.

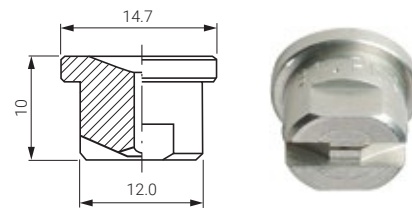

CONNECTION: flange

TYPICAL APPLICATIONS

Washing: semiconductor and precision parts cleaning

Cooling: continuous casting, product cooling

Lubrication: spray of lubricating oils and release agents

Other applications: spray of flavouring agents, cooling oil and antifoulant chemicals

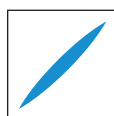

Spray section

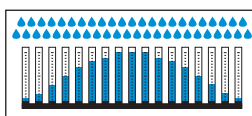

Convex distribution

GXD 25°	GXL 40°	GXN 50°	GXR 65°	CAPACITY CODE	D mm	Capacity at different pressure values (l/min) (bar)									
						0.7	1.0	1.5	2.0	3.0	4.0	5.0	7.0	10	
			•	0060	0.28	0.02	0.03	0.04	0.05	0.06	0.07	0.08	0.09	0.11	
			•	0100	0.34	0.05	0.06	0.07	0.08	0.10	0.12	0.13	0.15	0.18	
			•	0130	0.38	0.06	0.08	0.09	0.11	0.13	0.15	0.17	0.20	0.24	
•	•	•	•	0150	0.40	0.07	0.09	0.11	0.12	0.15	0.17	0.19	0.23	0.27	
•	•	•	•	0200	0.46	0.08	0.12	0.14	0.16	0.20	0.23	0.26	0.31	0.37	
•	•	•	•	0260	0.53	0.11	0.15	0.18	0.21	0.26	0.30	0.34	0.40	0.47	
•	•	•	•	0390	0.66	0.16	0.23	0.28	0.32	0.39	0.45	0.50	0.60	0.71	
•	•	•	•	0590	0.79	0.24	0.34	0.42	0.48	0.59	0.68	0.76	0.90	1.08	

GXS 75°	GXT 80°	GXV 95°	GXJ 110°	CAPACITY CODE	D mm	Capacity at different pressure values (l/min) (bar)									
						0.7	1.0	1.5	2.0	3.0	4.0	5.0	7.0	10	
•				0100	0.34	0.05	0.06	0.07	0.08	0.10	0.12	0.13	0.15	0.18	
•				0130	0.38	0.06	0.08	0.09	0.11	0.13	0.15	0.17	0.20	0.24	
•	•	•	•	0150	0.40	0.07	0.09	0.11	0.12	0.15	0.17	0.19	0.23	0.27	
•	•	•	•	0200	0.46	0.08	0.12	0.14	0.16	0.20	0.23	0.26	0.31	0.37	
•	•	•	•	0260	0.53	0.11	0.15	0.18	0.21	0.26	0.30	0.34	0.40	0.47	
•	•	•	•	0390	0.66	0.16	0.23	0.28	0.32	0.39	0.45	0.50	0.60	0.71	
•	•	•	•	0590	0.79	0.24	0.34	0.42	0.48	0.59	0.68	0.76	0.90	1.08	

ASSEMBLY FITTINGS

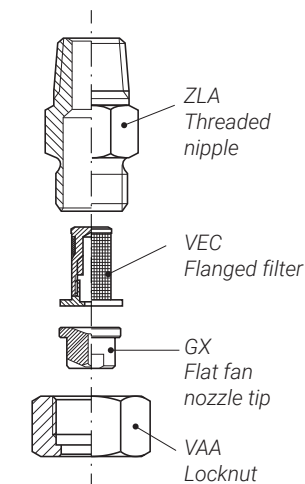

MATERIAL PROCESSING

Because of the extreme difficulty of working hard materials such as stainless steels with very small profile drills, not all the capacity sizes shown in the nozzle table are available in all materials. The table below shows the minimum capacity values we can produce for each given material. Please contact our sales for more information.

Material	0060	0100	0130	0150	0200	0260	0390	0590	0780
B31 - AISI 316L					•	•	•	•	•(1)
B1 - AISI 303	•	•	•	•	•	•	•	•	•(2)
T1 - Brass	•	•	•	•	•	•	•	•	•(2)

- (1) Low capacity body
- (2) Standard capacity body

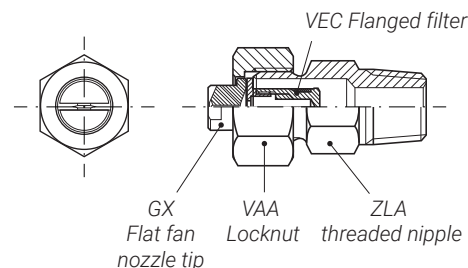

HOW TO MAKE UP THE NOZZLE CODE

Ex.: GXD 0390 B1

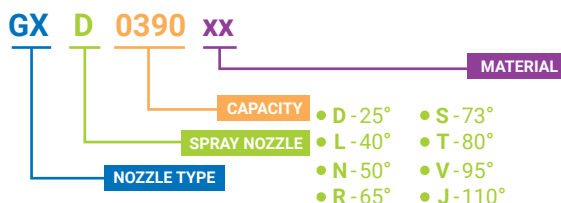

- B1 - AISI 303 Stainless steel
- B31 - AISI 316L Stainless steel
- T1 - Brass

# GX (FLAT FAN NOZZLE TIPS)

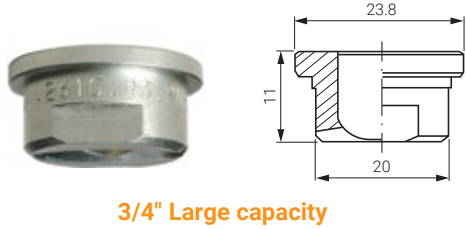
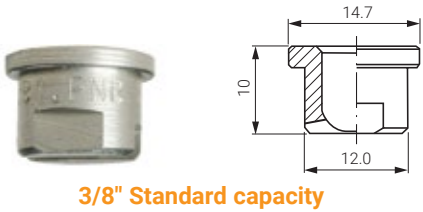

## STANDARD AND LARGE CAPACITIES

Flat fan nozzle tips are usually mounted onto a pipe by means of a welded 3/8" nipple or a clamp, and secured in place with a retaining nut. They can be easily replaced and their jet can be conveniently oriented in the desired direction. These nozzle are available in two types: 3/8" standard capacity and 3/4" large capacity. The tip is assembled with a pipe clamp, a welding nipple and a locknut.

CONNECTION: Flange

TYPICAL APPLICATIONS

- Washing:* filter cloth cleaning, parts cleaning, vehicles cleaning
- Cooling:* steel cooling, product cooling
- Lubrication:* spray of lubricating oil and release agents
- Other applications:* spray of antifoulant chemicals, etc.

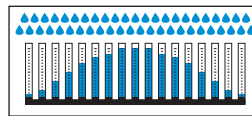

## 3/8" PLASTIC TIPS



**NEW** Also available in high quality PVDF

GXQ 60°	GXU 90°	GXJ 110°	CODE	D mm	(l/min) (bar)								
					0.5	1.0	1.5	2.0	3.0	4.0	5.0	7.0	10
		•	<b>0780</b>	0.91	0.32	0.45	0.55	0.64	0.78	0.90	1.01	1.19	1.42
•		•	<b>1120</b>	1.10	0.49	0.69	0.85	0.98	1.20	1.39	1.55	1.83	2.19
•	•	•	<b>1233</b>	1.50	0.95	1.35	1.65	1.90	2.33	2.69	3.01	3.56	4.25
	•	•	<b>1310</b>	1.70	1.27	1.79	2.19	2.53	3.10	3.58	4.00	4.74	5.66
	•	•	<b>1490</b>	2.10	2.00	2.83	3.46	4.00	4.90	5.66	6.33	7.48	8.95

## ASSEMBLY FITTINGS

In the table you can check the available 3/8" GX tips, manufactured in plastic material (D82 - molded PVDF).

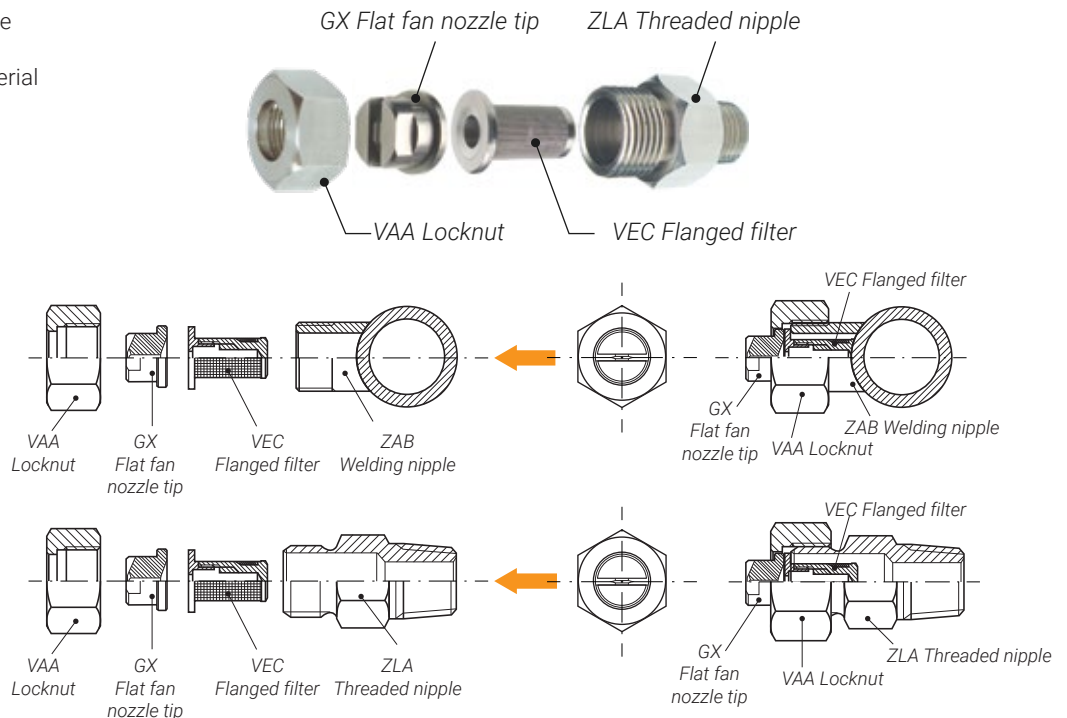

### HOW TO MAKE UP THE NOZZLE CODE

Ex.: GXA 1310 B1

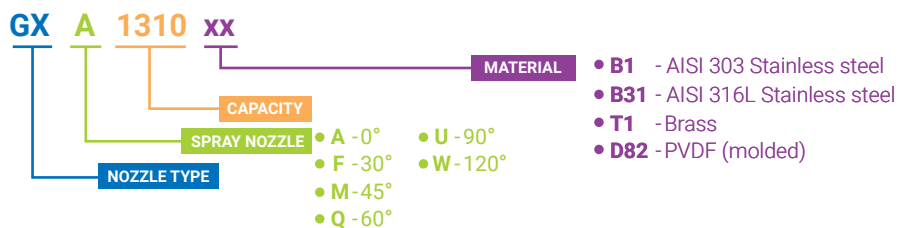



( FLAT FAN NOZZLES TIPS ) **GX**

3/8" STANDARD CAPACITY TIPS

GXA 0°	GXF 30°	GXM 45°	GXQ 60°	GXU 90°	GXW 120°	CODE	D mm	Capacity at different pressure values								(l/min) (bar)	
								0.5	1.0	1.5	2.0	3.0	4.0	5.0	7.0		10
								•	•	•	•	•	•	<b>0780</b>	0.91		0.32
•	•	•	•	•	•	<b>1120</b>	1.10	0.49	0.69	0.85	0.98	1.20	1.39	1.55	1.83	2.19	
•	•	•	•	•	•	<b>1160</b>	1.30	0.65	0.92	1.13	1.31	1.60	1.85	2.07	2.44	2.92	
•	•	•	•	•	•	<b>1190</b>	1.30	0.78	1.10	1.34	1.55	1.90	2.19	2.45	2.90	3.47	
•	•	•	•	•	•	<b>1233</b>	1.50	0.95	1.35	1.65	1.90	2.33	2.69	3.01	3.56	4.25	
•	•	•	•	•	•	<b>1310</b>	1.70	1.27	1.79	2.19	2.53	3.10	3.58	4.00	4.74	5.66	
•	•	•	•	•	•	<b>1385</b>	1.80	1.57	2.22	2.72	3.14	3.85	4.45	4.97	5.88	7.03	
•	•	•	•	•	•	<b>1490</b>	2.10	2.00	2.83	3.46	4.00	4.90	5.66	6.33	7.48	8.95	
•	•	•	•	•	•	<b>1581</b>	2.30	2.37	3.35	4.11	4.74	5.81	6.71	7.50	8.87	10.6	
•	•	•	•	•	•	<b>1780</b>	2.70	3.18	4.50	5.52	6.37	7.80	9.01	10.1	11.9	14.2	
•	•	•	•	•	•	<b>1980</b>	3.00	4.00	5.66	6.93	8.00	9.80	11.3	12.7	15.0	17.9	
•	•	•	•	•	•	<b>2124</b>	3.40	5.06	7.16	8.77	10.1	12.4	14.3	16.0	18.9	22.6	
•	•	•	•	•	•	<b>2153</b>	3.80	6.25	8.83	10.8	12.5	15.3	17.7	19.8	23.4	27.9	
•	•	•	•	•	•	<b>2194</b>	4.30	7.92	11.2	13.7	15.8	19.4	22.4	25.0	29.6	35.4	
•	•	•	•	•	•	<b>2245</b>	4.80	10.0	14.1	17.3	20.0	24.5	28.3	31.6	37.4	44.7	

**IMPORTANT**  
Nozzle **GXx 0780 B31** is made with "low capacity" body, while when it's fabricated with other materials is made with "standard capacity" body.

3/4" LARGE CAPACITY TIPS

GXA 0°	GXF 30°	GXM 45°	GXQ 60°	GXU 90°	GXW 120°	CODE	D mm	Capacity at different pressure values								(l/min) (bar)	
								0.5	1.0	1.5	2.0	3.0	4.0	5.0	7.0		10
								•	•	•	•	•	•	<b>1781</b>	2.70		3.18
•	•	•	•	•	•	<b>1981</b>	3.00	4.00	5.66	6.93	8.00	9.80	11.3	12.7	15.0	17.9	
•	•	•	•	•	•	<b>2125</b>	3.40	5.06	7.16	8.77	10.1	12.4	14.3	16.0	18.9	22.6	
•	•	•	•	•	•	<b>2154</b>	3.80	6.25	8.83	10.8	12.5	15.3	17.7	19.8	23.4	27.9	
•	•	•	•	•	•	<b>2195</b>	4.30	7.92	11.2	13.7	15.8	19.4	22.4	25.0	29.6	35.4	
•	•	•	•	•	•	<b>2246</b>	4.80	10.0	14.1	17.3	20.0	24.5	28.3	31.6	37.4	44.7	
•	•	•	•	•	•	<b>2311</b>	5.40	12.7	18.0	22.0	25.4	31.1	35.9	40.1	47.5	56.8	
•	•	•	•	•	•	<b>2490</b>	6.40	20.0	28.3	34.6	40.0	49.0	56.6	63.3	74.8	89.5	
•	•	•	•	•	•	<b>2610</b>	7.50	24.9	35.2	43.1	49.8	61.0	70.4	78.8	93.2	111	
•	•	•	•	•	•	<b>2760</b>	8.30	31.0	43.9	53.7	62.1	76.0	87.8	98.1	116	139	
•	•	•	•	•	•	<b>3122</b>	12.5	49.8	70.4	86.3	99.6	122	141	158	186	223	

ASSEMBLY FITTINGS CODING

Name	Code and material	Appearance	Standard size 3/8"	Large size 3/4"
Locknut <b>P.90</b>	<b>B1</b> - AISI 303 <b>B31</b> - AISI 316L <b>T1</b> - Brass <b>D6</b> - Fiberglass reinforced PP		VAA 0380 <b>xxB</b>	VAA 0750 <b>xxB</b>
Welding nipple <b>P.91</b>	<b>B1</b> - AISI 303 <b>B31</b> - AISI 316L		ZAA C018 <b>xxG</b>	ZAA E027 <b>xxG</b>
Threaded nipple <b>P.91</b>	<b>B1</b> - AISI 303 <b>B31</b> - AISI 316L <b>T1</b> - Brass		ZLA 2538 <b>xxB</b>	ZLA 7575 <b>xxB</b>
Metal pipe clamp <b>P.89</b>	<b>B1</b> - AISI 303 <b>T1</b> - Brass		ZPM	—
Plastic pipe clamp <b>P.88</b>	<b>D6</b> - Fiberglass reinforced PP		ZPB 0050 D6	—
Plastic bayonet pipe clamp <b>P.88</b>	<b>D82</b> - PVDF		ZPC 0500 D82P	—
Flanged filter <b>P.94</b>	<b>B1</b> - AISI 303 <b>B31</b> - AISI 316L <b>T1</b> - Brass <b>D3</b> - Polyamide		VEC 0138 <b>xx</b>	—

# GY ( DOVE-TAIL FLAT FAN TIPS )

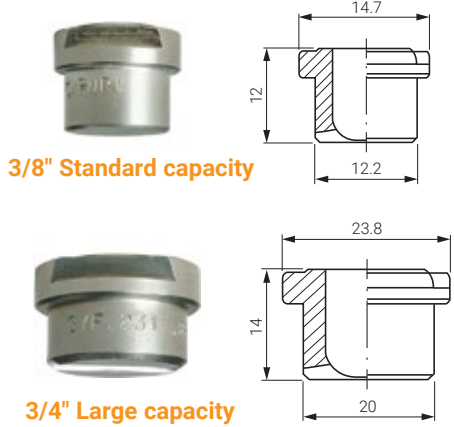

## STANDARD AND LARGE CAPACITIES

GY flat fan nozzle tips are usually mounted onto a pipe by means of a welding nipple and secured in place with a retaining nut. Therefore, they can be easily replaced and their dove-tail connection assures an always precise assembly as the nozzle can be assembled only when the flat fan is properly oriented. They are available in three types: 3/8" standard capacity, 3/4" large capacity and 1" extra-large capacity. The tip models shown on this page deliver the most popular capacity values, while GY flat fan tips with bigger capacities and sizes can be manufactured on request and supplied with matching dovetail nipples and retaining nuts. Please find information about instalment and accessories on page 91.

CONNECTION: Dovetail flat fan tips  
 TYPICAL APPLICATIONS  
 Washing: steel cleaning, filter cloth cleaning, parts cleaning  
 Cooling: steel cooling, product cooling



Spray section

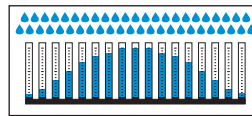

Convex distribution



## SPRAY ANGLE CODES

GYA	GYF	GYM	GYQ	GYU	GYW
0°	30°	45°	60°	90°	120°

## ASSEMBLY FITTINGS

The picture below shows a GY nozzle tip (in the middle) assembled with a dove-tail nipple (right) and a locknut (left).

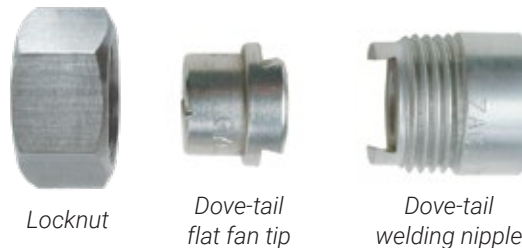

Locknut

Dove-tail flat fan tip

Dove-tail welding nipple

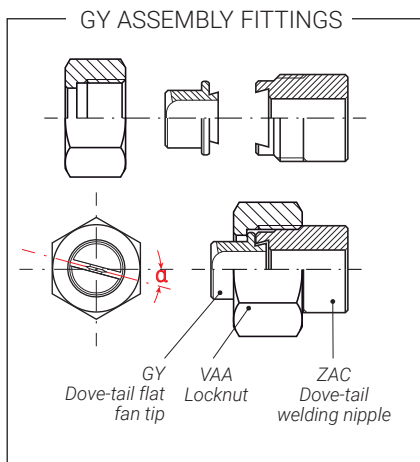

## NDOVE-TAIL NIPPLES

GY nozzle tips are assembled onto their own series of matching dovetail nipples, to assure perfect alignment: the two tip sizes require nipples and caps as shown in the table below.

The orientation of the spray jets, properly inclined to avoid their interfering, is automatically obtained welding the nipples in place with their dovetail aligned along the pipe axis. This is easily done by running a straight rule across the dovetail profile machined on the nipple.

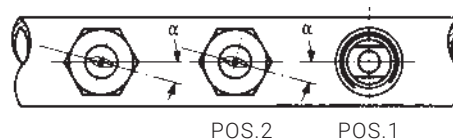

See values for jet deviation angle (α) beside capacity tables next page.

### HOW TO MAKE UP THE NOZZLE CODE

Ex.: GYF 1190 B1

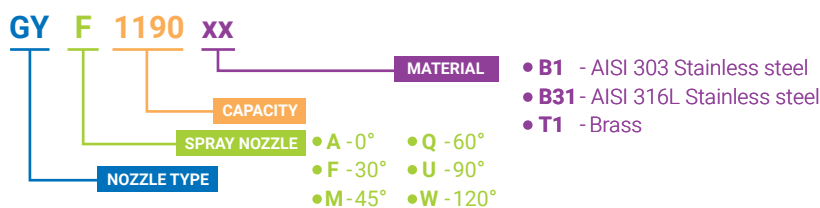

( DOVE-TAIL FLAT FAN TIPS ) **GY**

STANDARD AND LARGE CAPACITIES

3/8" STANDARD CAPACITY TIPS

Jet deviation angle  $\alpha = 5^\circ$

GYF 30°	GYM 45°	GYQ 60°	GYU 90°	GYW 120°	CAPACITY CODE	D mm	Capacity at different pressure values								(l/min) (bar)
							0.5	1.0	1.5	2.0	3.0	4.0	5.0	7.0	
•	•	•	•	•	<b>1190</b>	1.30	0.78	1.10	1.34	1.55	1.90	2.19	2.45	2.90	3.47
•	•	•	•	•	<b>1233</b>	1.50	0.95	1.35	1.65	1.90	2.33	2.69	3.01	3.56	4.25
•	•	•	•	•	<b>1310</b>	1.70	1.27	1.79	2.19	2.53	3.10	3.58	4.00	4.74	5.66
•	•	•	•	•	<b>1385</b>	1.80	1.57	2.22	2.72	3.14	3.85	4.45	4.97	5.88	7.03
•	•	•	•	•	<b>1490</b>	2.10	2.00	2.83	3.46	4.00	4.90	5.66	6.33	7.48	8.95
•	•	•	•	•	<b>1581</b>	2.30	2.37	3.35	4.11	4.74	5.81	6.71	7.50	8.87	10.6
•	•	•	•	•	<b>1780</b>	2.70	3.18	4.50	5.52	6.37	7.80	9.01	10.1	11.9	14.2
•	•	•	•	•	<b>1980</b>	3.00	4.00	5.66	6.93	8.00	9.80	11.3	12.7	15.0	17.9
•	•	•	•	•	<b>2124</b>	3.40	5.06	7.16	8.77	10.1	12.4	14.3	16.0	18.9	22.6
•	•	•	•	•	<b>2153</b>	3.80	6.25	8.83	10.8	12.5	15.3	17.7	19.8	23.4	27.9
•	•	•	•	•	<b>2194</b>	4.30	7.96	11.3	13.8	15.9	19.5	22.5	25.2	29.8	35.6

3/4" LARGE CAPACITY TIPS

Jet deviation angle  $\alpha = 15^\circ$

GYA 0°	GYF 30°	GYM 45°	GYQ 60°	GYU 90°	GYW 120°	CAPACITY CODE	D mm	Capacity at different pressure values								(l/min) (bar)
								0.5	1.0	1.5	2.0	3.0	4.0	5.0	7.0	
	•	•	•	•	•	<b>1781</b>	2.70	3.18	4.50	5.52	6.37	7.80	9.01	10.1	11.9	14.2
	•	•	•	•	•	<b>1981</b>	3.00	4.00	5.66	6.93	8.00	9.80	11.3	12.7	15.0	17.9
•	•	•	•	•	•	<b>2125</b>	3.40	5.06	7.16	8.77	10.1	12.4	14.3	16.0	18.9	22.6
•	•	•	•	•	•	<b>2154</b>	3.80	6.25	8.83	10.8	12.5	15.3	17.7	19.8	23.4	27.9
•	•	•	•	•	•	<b>2195</b>	4.30	7.92	11.2	13.7	15.8	19.4	22.4	25.0	29.6	35.4
•	•	•	•	•	•	<b>2246</b>	4.80	10.0	14.2	17.4	20.1	24.6	28.4	31.8	37.6	44.9
•	•	•	•	•	•	<b>2311</b>	5.40	12.7	18.0	22.0	25.4	31.1	35.9	40.1	47.5	56.8
•	•	•	•	•	•	<b>2490</b>	6.40	20.0	28.3	34.6	40.0	49.0	56.6	63.3	74.8	89.5
•	•	•	•	•	•	<b>2610</b>	7.50	24.9	35.2	43.1	49.8	61.0	70.4	78.8	93.2	111
	•	•	•	•	•	<b>2760</b>	8.30	31.0	43.9	53.7	62.1	76.0	87.8	98.1	116	139
	•	•	•	•	•	<b>3122</b>	12.5	49.8	70.4	86.3	99.6	122	141	158	186	223

ASSEMBLY FITTINGS CODING

Name	Material code	Appearance	Model no.	
			Standard size 3/8"	Large size 3/4"
Locknut <i>P.90</i>	<b>B1</b> - AISI 303 <b>B31</b> - AISI 316L <b>T1</b> - Ottone		VAA 0381 <b>xxB</b>	VAA 0750 <b>xxB</b>
Dove-tail welding nipple <i>P.91</i>	<b>B1</b> - AISI 303 <b>B31</b> - AISI 316L		ZAC C018 <b>xx</b>	ZAC E027 <b>xx</b>

HOW TO MAKE UP THE NOZZLE CODE

Ex.: GYF 1190 B1

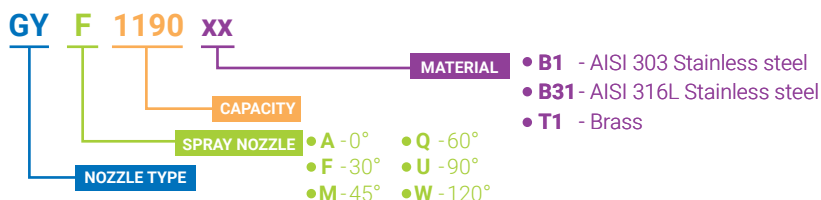

# HT ( QUICK-CONNECT FLAT FAN NOZZLES )

## STANDARD AND LARGE CAPACITY

The HT series flat fan nozzles offer the same quality and technical characteristics of the standard types but also the additional convenience of a bayonet coupling which allows a simple assembly with no need of tools and an automatic spray pattern alignment. The optimum performance of your system or machine is then conveniently safeguarded, with a noticeable reduction in service cost and production loss for system downtime. HT series are widely applied to working environments that are easy to clog. HT nozzles are available with low, *standard* and *large*.

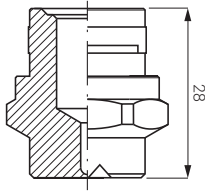
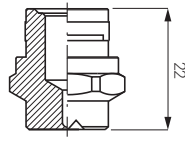

Spray section

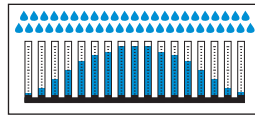

Convex distribution



### QUICK-CONNECT NOZZLES



HT + ZHS

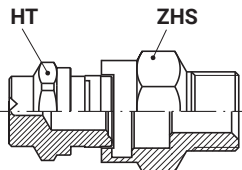

### TYPICAL APPLICATIONS

- Washing:**  
 Steel and PCB cleaning  
 Filter cloth cleaning
- Cooling:**  
 Steel cooling  
 Product cooling
- Other applications:**  
 Pre-treatment for coating process  
 Sewage treatment system

HTA 0°	HTL 40°	HTN 50°	HTR 65°	HTT 80°	HTV 95°	HTJ 110°	CODE	D mm	Capacity at different pressure values (l/min) (bar)						
									0.5	1.0	1.5	2.0	3.0	5.0	7.0

#### LOW CAPACITY TIPS

•	•	•	•	•	•	•	•	0260	0.53	0.11	0.15	0.18	0.21	0.26	0.34	0.40	0.47
•	•	•	•	•	•	•	•	0390	0.66	0.16	0.23	0.28	0.32	0.39	0.50	0.60	0.71
•	•	•	•	•	•	•	•	0590	0.79	0.24	0.34	0.42	0.48	0.59	0.76	0.90	1.08
•	•	•	•	•	•	•	•	0780	0.91	0.32	0.45	0.55	0.64	0.78	1.01	1.19	1.42
•	•	•	•	•	•	•	•	1120	1.10	0.49	0.69	0.85	0.98	1.20	1.55	1.83	2.19
•	•	•	•	•	•	•	•	1160	1.30	0.65	0.92	1.13	1.31	1.60	2.07	2.44	2.92
•	•	•	•	•	•	•	•	1190	1.30	0.78	1.10	1.34	1.55	1.90	2.45	2.90	3.50
•	•	•	•	•	•	•	•	1200	1.40	0.82	1.15	1.41	1.63	2.00	2.58	3.06	3.65
•	•	•	•	•	•	•	•	1230	1.50	0.94	1.33	1.63	1.88	2.30	2.97	3.51	4.20

#### STANDARD CAPACITY TIPS

•	•	•	•	•	•	•	•	1310	1.70	1.27	1.79	2.19	2.53	3.10	4.00	4.74	5.66
•	•	•	•	•	•	•	•	1385	1.80	1.57	2.22	2.72	3.14	3.85	4.97	5.88	7.03
•	•	•	•	•	•	•	•	1490	2.10	2.00	2.83	3.46	4.00	4.90	6.33	7.48	8.95
•	•	•	•	•	•	•	•	1581	2.30	2.37	3.35	4.11	4.74	5.81	7.50	8.87	10.6
•	•	•	•	•	•	•	•	1780	2.70	3.18	4.50	5.52	6.37	7.80	10.1	11.9	14.2
•	•	•	•	•	•	•	•	1980	3.00	4.00	5.66	6.93	8.00	9.80	12.7	15.0	17.9
•	•	•	•	•	•	•	•	2124	3.40	5.06	7.16	8.77	10.1	12.4	16.0	18.9	22.6
•	•	•	•	•	•	•	•	2153	3.80	6.25	8.83	10.8	12.5	15.3	19.8	23.4	27.9
•	•	•	•	•	•	•	•	2194	4.30	7.96	11.3	13.8	15.9	19.5	25.2	29.8	35.6

#### HIGH CAPACITY TIPS

•	•	•	•	•	•	•	•	2310	5.40	12.7	17.9	21.9	25.3	31.0	40.0	47.4	56.6
•	•	•	•	•	•	•	•	2390	6.00	15.9	22.5	27.6	31.8	39.0	50.3	59.6	71.2
•	•	•	•	•	•	•	•	2470	6.60	19.2	27.1	33.2	38.4	47.0	60.7	71.8	85.8
•	•	•	•	•	•	•	•	2590	7.50	24.1	34.1	41.7	48.2	59.0	76.2	90.1	108
•	•	•	•	•	•	•	•	2780	8.70	31.8	45.0	55.2	63.7	78.0	101	119	142

#### ACCESSORIES

We offer various specification and materials of nipples. Please see below ordering code

Name	Thread (RG) inch	Standard size	Large size	H mm	WS mm	D mm
Male nipple	1/4"	ZHS 0025 xxQ1	-	29	22	-
	3/8"	ZHS 0038 xxQ1	-	29	22	-
	1/2"	-	ZHS 0050 xxQ2	35	30	-
Female nipple	3/8"	ZHT 0038 xxQ1	-	29	22	-
Welding nipple	-	ZHU 0038 xxQ1	ZHU 0050 xxQ2	32	-	28
Seal (Viton) for SS nipples	-	VDH BQ10 E7	VDH BQ20 E7	-	-	-
GSeal (BUNA) for brass nipples	-	VDH BQ10 E8	VDH BQ20 E8	-	-	-

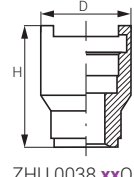
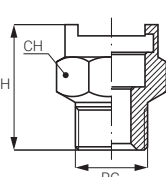

ZHU 0038 xxQ1

ZHS 0025 xxQ1

ZHS 0050 xxQ2

#### HOW TO MAKE UP THE NOZZLE CODE

Ex.: HTA 1310 B1

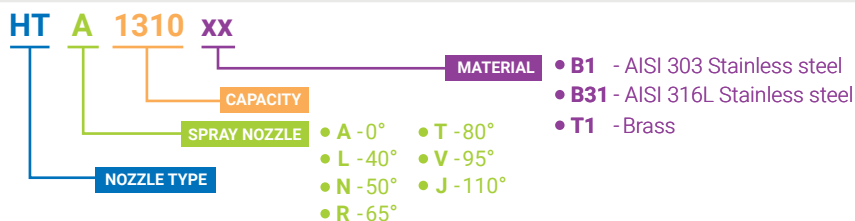

( LOW FLOW FLAT FAN NOZZLES ) J

LOW FLOW FLAT FAN NOZZLES

These standard flat fan nozzles are available in a wide range of capacities, spray angles and materials. Nozzles shown on this page cover the low to minimal capacity range from 0.06 to 1.60 litres per minute. The tiny outlet orifices, machined with high precision, may require to be protected from clogging by means of an adequate filter positioned inside the supply line, depending upon the quantity and type of the solid particles suspended in the liquid. These nozzles can be made with a customized inner thread for a VEF filter (\*optional). We suggest to buy these nozzles with their related VEF filter.

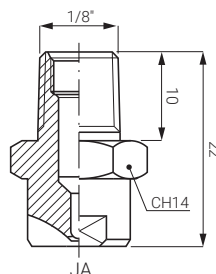
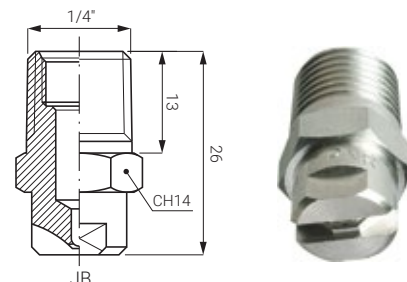

THREAD SPECIFICATION: BSPT, NPT  
 TYPICAL APPLICATIONS  
 Washing: steel and PCB cleaning, glass substrate cleaning  
 Cooling: steel cooling, product cooling  
 Other applications: pre-treatment for coating process, sewage treatment system

J nozzles series are also available with NPT thread: the code becomes H.

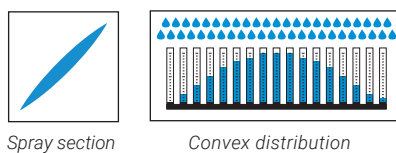

Spray angle	25°	40°	50°	65°	75°	80°	95°	110°	CAPACITY CODE	D mm	Capacity at different pressure values (l/min) (bar)							
	1/8"	JAD	JAL	JAN	JAR	JAS	JAT	JAV			JAJ	0.7	1.0	1.5	2.0	3.0	5.0	7.0
1/4"	JBD	JBL	JBN	JBR	JBS	JBT	JBV	JB										
0100				•					0100	0.34	0.048	0.06	0.07	0.08	0.10	0.13	0.15	0.18
0130				•					0130	0.38	0.06	0.08	0.09	0.11	0.13	0.17	0.20	0.24
0150	•	•	•	•	•	•	•	•	0150	0.40	0.07	0.09	0.11	0.12	0.15	0.19	0.23	0.27
0200	•	•	•	•	•	•	•	•	0200	0.46	0.096	0.12	0.14	0.16	0.20	0.26	0.31	0.37
0260	•	•	•	•	•	•	•	•	0260	0.53	0.10	0.15	0.18	0.21	0.26	0.34	0.40	0.47
0390	•	•	•	•	•	•	•	•	0390	0.66	0.19	0.23	0.28	0.32	0.39	0.50	0.60	0.71
0590	•	•	•	•	•	•	•	•	0590	0.79	0.28	0.34	0.42	0.48	0.59	0.76	0.90	1.08

LIMIT OF MATERIALS PROCESSING

Hard materials such as stainless steel are extremely difficult to work with small profile drills, therefore not all nozzle sizes are available in all materials. Our sales office will offer you the best choice according to the materials and specifications you require.

Material	0100	0130	0150	0200	0260	0390	0590	0780
B31 - AISI 316L				•	•	•	•	•(1)
B1 - AISI 303	•	•	•	•	•	•	•	•(2)
T1 - Brass	•	•	•	•	•	•	•	•(2)

- (1) Low capacity body
- (2) Standard capacity body

VEF THREADED FILTERS (OPTIONAL)

J series small capacity nozzles have a small diameter and can work with clean liquids. So, if you order small capacity nozzles, we suggest you to order VEF threaded filters too, to avoid clogging.

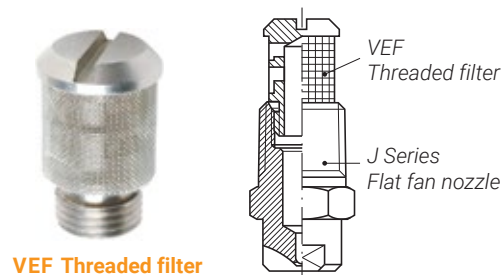

Nozzle type	Thread filter code	Thread size
JA (1/8")	VEF 0411 xx	M7
JB (1/4")	VEF 0138 xx	3/8"UNF

HOW TO MAKE UP THE NOZZLE CODE

Ex.: JAD 0130 B1

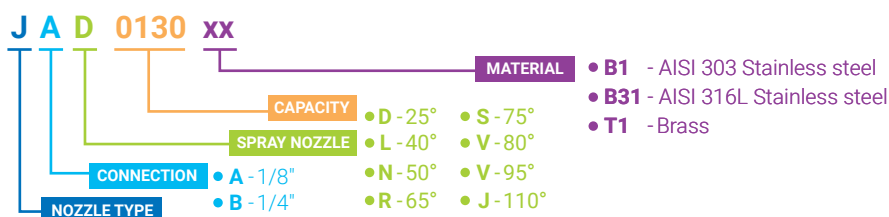

# J ( STANDARD CAPACITY FLAT FAN NOZZLES )

## STANDARD CAPACITY FLAT FAN NOZZLES

Standard flat fan nozzles are available in a wide range of different capacities, spray angles, thread sizes and materials. Used in several industrial applications, they produce a mist spray and supply an appropriate force of impact.

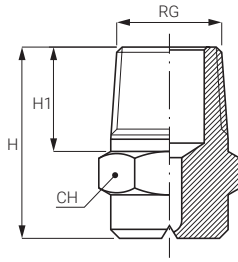

### TYPICAL APPLICATIONS

- Washing:* parts cleaning, food cleaning, filter cloth cleaning
  - Spray:* spray of chemicals, disinfectant and lubricating fluids
  - Cooling:* metal parts and vehicles cooling
  - Other applications:* water curtain for toxic gases separation, cleaning systems
- In steelworks they are used in the pickling process to remove surface oxides layers formed during the hot metalwork.

THREAD SPECIFICATION: BSPT, NPT



Spray section

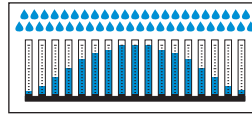

Convex distribution



### SPRAY ANGLE CODES

JxA	0°
JxC	20°
JxF	30°
JxM	45°
JxQ	60°
JxU	90°
JxW	120°

### THREAD SIZE CODES (RG)

JA	1/8"
JB	1/4"
JC	3/8"

SPRAY ANGLE	JAA 1/8"	JBA 1/4"	JCA 3/8"	CAPACITY CODE	D mm	Capacity at different pressure values								(l/min) (bar)	
						0.5	1.0	2.0	3.0	4.0	5.0	7.0	10	20	
0°	•	•		0780	0.91	0.32	0.45	0.64	0.78	0.90	1.01	1.19	1.42	2.01	
	•	•		1120	1.10	0.49	0.69	0.98	1.20	1.39	1.55	1.83	2.19	3.10	
	•	•		1160	1.30	0.65	0.92	1.31	1.60	1.85	2.07	2.44	2.92	4.13	
	•	•		1190	1.30	0.78	1.10	1.55	1.90	2.19	2.45	2.90	3.47	4.91	
	•	•		1233	1.50	0.95	1.35	1.90	2.33	2.69	3.01	3.56	4.25	6.02	
	•	•		1310	1.70	1.27	1.79	2.53	3.10	3.58	4.00	4.74	5.66	8.00	
	•	•		1385	1.80	1.57	2.22	3.14	3.85	4.45	4.97	5.88	7.03	9.94	
	•	•		1490	2.10	2.00	2.83	4.00	4.90	5.66	6.33	7.48	8.95	12.7	
	•	•		1581	2.30	2.37	3.35	4.74	5.81	6.71	7.50	8.87	10.6	15.0	
	•	•	•	1780	2.70	3.18	4.50	6.37	7.80	9.01	10.1	11.9	14.2	20.1	
	•	•	•	1980	3.00	4.00	5.66	8.00	9.80	11.3	12.7	15.0	17.9	25.3	
	•	•	•	2124	3.40	5.06	7.16	10.1	12.4	14.3	16.0	18.9	22.6	32.0	
	•	•	•	2153	3.80	6.25	8.83	12.5	15.3	17.7	19.8	23.4	27.9	39.5	
	•	•	•	2195	4.30	7.96	11.3	15.9	19.5	22.5	25.2	29.8	35.6	50.3	
	•	•	•	2245	4.80	10.0	14.1	20.0	24.5	28.3	31.6	37.4	44.7	63.3	
•	•	•	2274	5.20	11.2	15.8	22.4	27.4	31.6	35.4	41.9	50.0	70.7		
•	•	•	2310	5.40	12.7	17.9	25.3	31.0	35.8	40.0	47.4	56.6	80.0		
•	•	•	2390	6.00	15.9	22.5	31.8	39.0	45.0	50.3	59.6	71.2	101		
•	•	•	2470	6.20	19.2	27.1	38.4	47.0	54.3	60.7	71.8	85.8	121		

### DIMENSIONS AND WEIGHTS

CODE	Dimension (RG)	H	H1	CH	W
Type	inch	mm	mm	mm	gr
JA	1/8"	19.5	11	12	9
JB	1/4"	22.0	12	14	18
JC	3/8"	25.0	14	17	34

### IMPORTANT

The nozzle **Jxx 0780 B31** is made with "low capacity" body, while when it's fabricated with other materials is made with "standard capacity" body.

### HOW TO MAKE UP THE NOZZLE CODE

Ex.: JAA 1153 B1

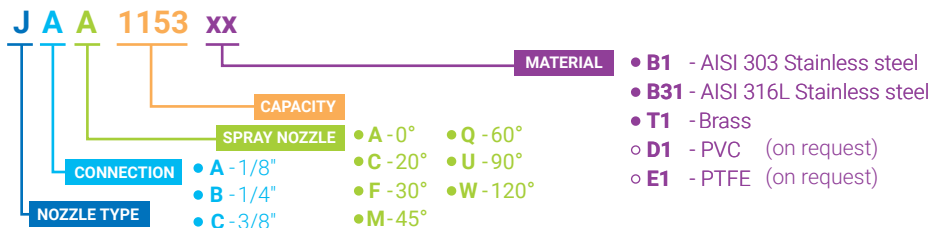



( STANDARD CAPACITY FLAT FAN NOZZLES ) J

D	Capacity at different pressure values (l/min) (bar)	0.5	1.0	2.0	3.0	4.0	5.0	7.0	10	20	
											JAC 1/8"
20°	• • • • • • • • • • • • • • • •	0.91	0.32	0.45	0.64	0.78	0.90	1.01	1.19	1.42	2.01
	• • • • • • • • • • • • • • • •	1.10	0.49	0.69	0.98	1.20	1.39	1.55	1.83	2.19	3.10
	• • • • • • • • • • • • • • • •	1.30	0.65	0.92	1.31	1.60	1.85	2.07	2.44	2.92	4.13
	• • • • • • • • • • • • • • • •	1.30	0.78	1.10	1.55	1.90	2.19	2.45	2.90	3.47	4.91
	• • • • • • • • • • • • • • • •	1.50	0.95	1.35	1.90	2.33	2.69	3.01	3.56	4.25	6.02
	• • • • • • • • • • • • • • • •	1.70	1.27	1.79	2.53	3.10	3.58	4.00	4.74	5.66	8.00
	• • • • • • • • • • • • • • • •	1.80	1.57	2.22	3.14	3.85	4.45	4.97	5.88	7.03	9.94
	• • • • • • • • • • • • • • • •	2.10	2.00	2.83	4.00	4.90	5.66	6.33	7.48	8.95	12.7
	• • • • • • • • • • • • • • • •	2.30	2.37	3.35	4.74	5.81	6.71	7.50	8.87	10.6	15.0
	• • • • • • • • • • • • • • • •	2.70	3.18	4.50	6.37	7.80	9.01	10.1	11.9	14.2	20.1
	• • • • • • • • • • • • • • • •	3.00	4.00	5.66	8.00	9.80	11.3	12.7	15.0	17.9	25.3
	• • • • • • • • • • • • • • • •	3.40	5.06	7.16	10.1	12.4	14.3	16.0	18.9	22.6	32.0
	• • • • • • • • • • • • • • • •	3.80	6.25	8.83	12.5	15.3	17.7	19.8	23.4	27.9	39.5
	• • • • • • • • • • • • • • • •	4.30	7.96	11.3	15.9	19.5	22.5	25.2	29.8	35.6	50.3
	• • • • • • • • • • • • • • • •	4.80	10.0	14.1	20.0	24.5	28.3	31.6	37.4	44.7	63.3
	• • • • • • • • • • • • • • • •	5.20	11.2	15.8	22.4	27.4	31.6	35.4	41.9	50.0	70.7
• • • • • • • • • • • • • • • •	5.40	12.7	17.9	25.3	31.0	35.8	40.0	47.4	56.6	80.0	
• • • • • • • • • • • • • • • •	6.00	15.9	22.5	31.8	39.0	45.0	50.3	59.6	71.2	101	
• • • • • • • • • • • • • • • •	6.20	19.2	27.1	38.4	47.0	54.3	60.7	71.8	85.8	121	

SPRAY ANGLE CODES

JxA	0°
JxC	20°
JxF	30°
JxM	45°
JxQ	60°
JxU	90°
JxW	120°

THREAD SIZE CODES (RG)

JA	1/8"
JB	1/4"
JC	3/8"

IMPORTANT

The nozzle **Jxx 0780 B31** is made with "low capacity" body, while when it's fabricated with other materials is made with "standard capacity" body.

D	Capacity at different pressure values (l/min) (bar)	0.5	1.0	2.0	3.0	4.0	5.0	7.0	10	20	
											JAF
30°	• • • • • • • • • • • • • • • •	0.91	0.32	0.45	0.64	0.78	0.90	1.01	1.19	1.42	2.01
	• • • • • • • • • • • • • • • •	1.10	0.49	0.69	0.98	1.20	1.39	1.55	1.83	2.19	3.10
	• • • • • • • • • • • • • • • •	1.30	0.65	0.92	1.31	1.60	1.85	2.07	2.44	2.92	4.13
	• • • • • • • • • • • • • • • •	1.30	0.78	1.10	1.55	1.90	2.19	2.45	2.90	3.47	4.91
	• • • • • • • • • • • • • • • •	1.50	0.95	1.35	1.90	2.33	2.69	3.01	3.56	4.25	6.02
	• • • • • • • • • • • • • • • •	1.70	1.27	1.79	2.53	3.10	3.58	4.00	4.74	5.66	8.00
	• • • • • • • • • • • • • • • •	1.80	1.57	2.22	3.14	3.85	4.45	4.97	5.88	7.03	9.94
	• • • • • • • • • • • • • • • •	2.10	2.00	2.83	4.00	4.90	5.66	6.33	7.48	8.95	12.7
	• • • • • • • • • • • • • • • •	2.30	2.37	3.35	4.74	5.81	6.71	7.50	8.87	10.6	15.0
	• • • • • • • • • • • • • • • •	2.70	3.18	4.50	6.37	7.80	9.01	10.1	11.9	14.2	20.1
	• • • • • • • • • • • • • • • •	3.00	4.00	5.66	8.00	9.80	11.3	12.7	15.0	17.9	25.3
	• • • • • • • • • • • • • • • •	3.40	5.06	7.16	10.1	12.4	14.3	16.0	18.9	22.6	32.0
	• • • • • • • • • • • • • • • •	3.80	6.25	8.83	12.5	15.3	17.7	19.8	23.4	27.9	39.5
	• • • • • • • • • • • • • • • •	4.30	7.96	11.3	15.9	19.5	22.5	25.2	29.8	35.6	50.3
	• • • • • • • • • • • • • • • •	4.80	10.0	14.1	20.0	24.5	28.3	31.6	37.4	44.7	63.3
	• • • • • • • • • • • • • • • •	5.20	11.2	15.8	22.4	27.4	31.6	35.4	41.9	50.0	70.7
• • • • • • • • • • • • • • • •	5.40	12.7	17.9	25.3	31.0	35.8	40.0	47.4	56.6	80.0	
• • • • • • • • • • • • • • • •	6.00	15.9	22.5	31.8	39.0	45.0	50.3	59.6	71.2	101	
• • • • • • • • • • • • • • • •	6.20	19.2	27.1	38.4	47.0	54.3	60.7	71.8	85.8	121	

D	Capacity at different pressure values (l/min) (bar)	0.5	1.0	2.0	3.0	4.0	5.0	7.0	10	20	
											JAM
45°	• • • • • • • • • • • • • • • •	0.91	0.32	0.45	0.64	0.78	0.90	1.01	1.19	1.42	2.01
	• • • • • • • • • • • • • • • •	1.10	0.49	0.69	0.98	1.20	1.39	1.55	1.83	2.19	3.10
	• • • • • • • • • • • • • • • •	1.30	0.65	0.92	1.31	1.60	1.85	2.07	2.44	2.92	4.13
	• • • • • • • • • • • • • • • •	1.30	0.78	1.10	1.55	1.90	2.19	2.45	2.90	3.47	4.91
	• • • • • • • • • • • • • • • •	1.50	0.95	1.35	1.90	2.33	2.69	3.01	3.56	4.25	6.02
	• • • • • • • • • • • • • • • •	1.70	1.27	1.79	2.53	3.10	3.58	4.00	4.74	5.66	8.00
	• • • • • • • • • • • • • • • •	1.80	1.57	2.22	3.14	3.85	4.45	4.97	5.88	7.03	9.94
	• • • • • • • • • • • • • • • •	2.10	2.00	2.83	4.00	4.90	5.66	6.33	7.48	8.95	12.7
	• • • • • • • • • • • • • • • •	2.30	2.37	3.35	4.74	5.81	6.71	7.50	8.87	10.6	15.0
	• • • • • • • • • • • • • • • •	2.70	3.18	4.50	6.37	7.80	9.01	10.1	11.9	14.2	20.1
	• • • • • • • • • • • • • • • •	3.00	4.00	5.66	8.00	9.80	11.3	12.7	15.0	17.9	25.3
	• • • • • • • • • • • • • • • •	3.40	5.06	7.16	10.1	12.4	14.3	16.0	18.9	22.6	32.0
	• • • • • • • • • • • • • • • •	3.80	6.25	8.83	12.5	15.3	17.7	19.8	23.4	27.9	39.5
	• • • • • • • • • • • • • • • •	4.30	7.96	11.3	15.9	19.5	22.5	25.2	29.8	35.6	50.3
	• • • • • • • • • • • • • • • •	4.80	10.0	14.1	20.0	24.5	28.3	31.6	37.4	44.7	63.3
	• • • • • • • • • • • • • • • •	5.20	11.2	15.8	22.4	27.4	31.6	35.4	41.9	50.0	70.7
• • • • • • • • • • • • • • • •	5.40	12.7	17.9	25.3	31.0	35.8	40.0	47.4	56.6	80.0	
• • • • • • • • • • • • • • • •	6.00	15.9	22.5	31.8	39.0	45.0	50.3	59.6	71.2	101	
• • • • • • • • • • • • • • • •	6.20	19.2	27.1	38.4	47.0	54.3	60.7	71.8	85.8	121	

HOW TO MAKE UP THE NOZZLE CODE

Ex.: JAC 1153 B1

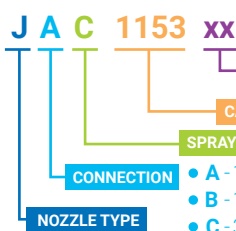

- B1 - AISI 303 Stainless steel
- B31 - AISI 316L Stainless steel
- T1 - Brass
- D1 - PVC (on request)
- E1 - PTFE (on request)

# J ( STANDARD CAPACITY FLAT FAN NOZZLES )

SPRAY ANGLE CODES

JxA	0°
JxC	20°
JxF	30°
JxM	45°
JxQ	60°
JxU	90°
JxW	120°

THREAD SIZE CODES (RG)

JA	1/8"
JB	1/4"
JC	3/8"

SPRAY ANGLE	JAQ 1/8"	JBQ 1/4"	JCQ 3/8"	CAPACITY CODE	D mm	Capacity at different pressure values								(l/min) (bar)	
						0.5	1.0	2.0	3.0	4.0	5.0	7.0	10	20	
60°	•	•		0780	0.91	0.32	0.45	0.64	0.78	0.90	1.01	1.19	1.42	2.01	
	•	•		1120	1.10	0.49	0.69	0.98	1.20	1.39	1.55	1.83	2.19	3.10	
	•	•		1160	1.30	0.65	0.92	1.31	1.60	1.85	2.07	2.44	2.92	4.13	
	•	•		1190	1.30	0.78	1.10	1.55	1.90	2.19	2.45	2.90	3.47	4.91	
	•	•		1233	1.50	0.95	1.35	1.90	2.33	2.69	3.01	3.56	4.25	6.02	
	•	•		1310	1.70	1.27	1.79	2.53	3.10	3.58	4.00	4.74	5.66	8.00	
	•	•		1385	1.80	1.57	2.22	3.14	3.85	4.45	4.97	5.88	7.03	9.94	
	•	•		1490	2.10	2.00	2.83	4.00	4.90	5.66	6.33	7.48	8.95	12.7	
	•	•		1581	2.30	2.37	3.35	4.74	5.81	6.71	7.50	8.87	10.6	15.0	
	•	•	•	1780	2.70	3.18	4.50	6.37	7.80	9.01	10.1	11.9	14.2	20.1	
	•	•	•	1980	3.00	4.00	5.66	8.00	9.80	11.3	12.7	15.0	17.9	25.3	
	•	•	•	2124	3.40	5.06	7.16	10.1	12.4	14.3	16.0	18.9	22.6	32.0	
	•	•	•	2153	3.80	6.25	8.83	12.5	15.3	17.7	19.8	23.4	27.9	39.5	
	•	•	•	2195	4.30	7.96	11.3	15.9	19.5	22.5	25.2	29.8	35.6	50.3	
	•	•	•	2245	4.80	10.0	14.1	20.0	24.5	28.3	31.6	37.4	44.7	63.3	
	•	•	•	2274	5.20	11.2	15.8	22.4	27.4	31.6	35.4	41.9	50.0	70.7	
•	•	•	2310	5.40	12.7	17.9	25.3	31.0	35.8	40.0	47.4	56.6	80.0		
•	•	•	2390	6.00	15.9	22.5	31.8	39.0	45.0	50.3	59.6	71.2	101		
•	•	•	2470	6.20	19.2	27.1	38.4	47.0	54.3	60.7	71.8	85.8	121		

**IMPORTANT**

The nozzle **Jxx 0780 B31** is made with "low capacity" body, while when it's fabricated with other materials is made with "standard capacity" body.

SPRAY ANGLE	JAU	JBU	JCU	CODE	D	0.5	1.0	2.0	3.0	4.0	5.0	7.0	10	20
90°	•	•		0780	0.91	0.32	0.45	0.64	0.78	0.90	1.01	1.19	1.42	2.01
	•	•		1120	1.10	0.49	0.69	0.98	1.20	1.39	1.55	1.83	2.19	3.10
	•	•		1160	1.30	0.65	0.92	1.31	1.60	1.85	2.07	2.44	2.92	4.13
	•	•		1190	1.30	0.78	1.10	1.55	1.90	2.19	2.45	2.90	3.47	4.91
	•	•		1233	1.50	0.95	1.35	1.90	2.33	2.69	3.01	3.56	4.25	6.02
	•	•		1310	1.70	1.27	1.79	2.53	3.10	3.58	4.00	4.74	5.66	8.00
	•	•		1385	1.80	1.57	2.22	3.14	3.85	4.45	4.97	5.88	7.03	9.94
	•	•		1490	2.10	2.00	2.83	4.00	4.90	5.66	6.33	7.48	8.95	12.7
	•	•		1581	2.30	2.37	3.35	4.74	5.81	6.71	7.50	8.87	10.6	15.0
	•	•	•	1780	2.70	3.18	4.50	6.37	7.80	9.01	10.1	11.9	14.2	20.1
	•	•	•	1980	3.00	4.00	5.66	8.00	9.80	11.3	12.7	15.0	17.9	25.3
	•	•	•	2124	3.40	5.06	7.16	10.1	12.4	14.3	16.0	18.9	22.6	32.0
	•	•	•	2153	3.80	6.25	8.83	12.5	15.3	17.7	19.8	23.4	27.9	39.5
	•	•	•	2195	4.30	7.96	11.3	15.9	19.5	22.5	25.2	29.8	35.6	50.3
	•	•	•	2245	4.80	10.0	14.1	20.0	24.5	28.3	31.6	37.4	44.7	63.3
	•	•	•	2274	5.20	11.2	15.8	22.4	27.4	31.6	35.4	41.9	50.0	70.7
•	•	•	2310	5.40	12.7	17.9	25.3	31.0	35.8	40.0	47.4	56.6	80.0	
•	•	•	2390	6.00	15.9	22.5	31.8	39.0	45.0	50.3	59.6	71.2	101	
•	•	•	2470	6.20	19.2	27.1	38.4	47.0	54.3	60.7	71.8	85.8	121	

SPRAY ANGLE	JAW	JBW	JCW	CODE	D	0.5	1.0	2.0	3.0	4.0	5.0	7.0	10	20
120°	•	•		0780	0.91	0.32	0.45	0.64	0.78	0.90	1.01	1.19	1.42	2.01
	•	•		1120	1.10	0.49	0.69	0.98	1.20	1.39	1.55	1.83	2.19	3.10
	•	•		1160	1.30	0.65	0.92	1.31	1.60	1.85	2.07	2.44	2.92	4.13
	•	•		1190	1.30	0.78	1.10	1.55	1.90	2.19	2.45	2.90	3.47	4.91
	•	•		1233	1.50	0.95	1.35	1.90	2.33	2.69	3.01	3.56	4.25	6.02
	•	•		1310	1.70	1.27	1.79	2.53	3.10	3.58	4.00	4.74	5.66	8.00
	•	•		1385	1.80	1.57	2.22	3.14	3.85	4.45	4.97	5.88	7.03	9.94
	•	•		1490	2.10	2.00	2.83	4.00	4.90	5.66	6.33	7.48	8.95	12.7
	•	•		1581	2.30	2.37	3.35	4.74	5.81	6.71	7.50	8.87	10.6	15.0
	•	•	•	1780	2.70	3.18	4.50	6.37	7.80	9.01	10.1	11.9	14.2	20.1
	•	•	•	1980	3.00	4.00	5.66	8.00	9.80	11.3	12.7	15.0	17.9	25.3
	•	•	•	2124	3.40	5.06	7.16	10.1	12.4	14.3	16.0	18.9	22.6	32.0
	•	•	•	2153	3.80	6.25	8.83	12.5	15.3	17.7	19.8	23.4	27.9	39.5
	•	•	•	2195	4.30	7.96	11.3	15.9	19.5	22.5	25.2	29.8	35.6	50.3
	•	•	•	2245	4.80	10.0	14.1	20.0	24.5	28.3	31.6	37.4	44.7	63.3
	•	•	•	2274	5.20	11.2	15.8	22.4	27.4	31.6	35.4	41.9	50.0	70.7
•	•	•	2310	5.40	12.7	17.9	25.3	31.0	35.8	40.0	47.4	56.6	80.0	
•	•	•	2390	6.00	15.9	22.5	31.8	39.0	45.0	50.3	59.6	71.2	101	
•	•	•	2470	6.20	19.2	27.1	38.4	47.0	54.3	60.7	71.8	85.8	121	

**HOW TO MAKE UP THE NOZZLE CODE**

Ex.: JAA 1153 B1

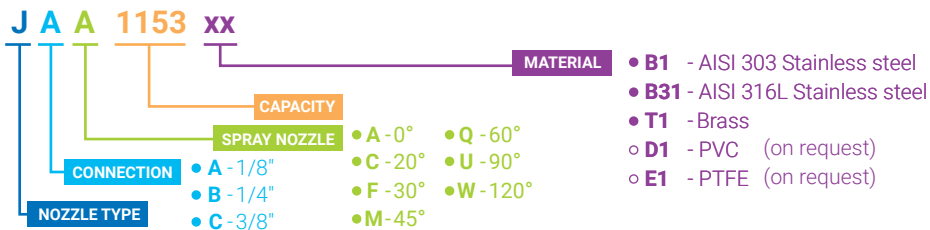

# ( LARGE CAPACITY FLAT FAN NOZZLES ) J

## LARGE CAPACITY FLAT FAN NOZZLES

J series standard flat fan nozzles are available in a wide range of different capacities, spray angles, thread sizes and materials. The large capacity models produce a high-impact spray jet with a mist effect and a powerful washing action.



THREAD SPECIFICATION: BSPT, NPT



Spray section

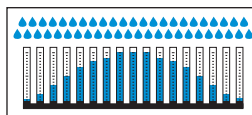

Convex distribution

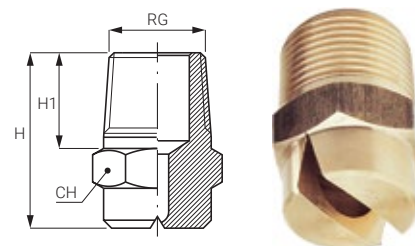

Spray Angle	1/2"	3/4"	1"	CODE	Capacity at different pressure values (l/min) (bar)									
					0.5	1.0	2.0	3.0	4.0	5.0	7.0	10	20	
0°	•			JDA 2590 xx	24.1	34.1	48.2	59.0	68.1	76.2	90.1	108	152	
	•			JDA 2780 xx	31.8	45.0	63.7	78.0	90.1	101	119	142	201	
		•		JEA 3134 xx	54.7	77.4	109	134	155	173	205	245	346	
		•		JEA 3275 xx	112	159	225	275	318	355	420	502	710	
			•	JFA 3390 xx	159	225	318	390	450	503	596	712	1007	
15°			•	JFA 3435 xx	178	251	355	435	502	562	664	794	1123	
	•			JDB 2195 xx	7.96	11.3	15.9	19.5	22.5	25.2	29.8	35.6	50.3	
	•			JDB 2274 xx	11.2	15.8	22.4	27.4	31.6	35.4	41.9	50.0	70.7	
25°		•		JDB 2390 xx	15.9	22.5	31.8	39.0	45.0	50.3	59.6	71.2	101	
	•			JEB 2990 xx	40.4	57.2	80.8	99.0	114	128	151	181	256	
	•			JDD 2390 xx	15.9	22.5	31.8	39.0	45.0	50.3	59.6	71.2	101	
	•			JDD 2590 xx	24.1	34.1	48.2	59.0	68.1	76.2	90.1	108	152	
40°			•	JDD 2780 xx	31.8	45.0	63.7	78.0	90.1	101	119	142	201	
	•			JFD 3195 xx	79.6	113	159	195	225	252	298	356	503	
	•			JDL 2195 xx	7.96	11.3	15.9	19.5	22.5	25.2	29.8	35.6	50.3	
	•			JDL 2240 xx	9.80	13.9	19.6	24.0	27.7	31.0	36.7	43.8	62.0	
	•			JDL 2274 xx	11.2	15.8	22.4	27.4	31.6	35.4	41.9	50.0	70.7	
50°			•	JDL 2390 xx	15.9	22.5	31.8	39.0	45.0	50.3	59.6	71.2	101	
	•			JDL 2590 xx	24.1	34.1	48.2	59.0	68.1	76.2	90.1	108	152	
	•			JDN 2274 xx	11.2	15.8	22.4	27.4	31.6	35.4	41.9	50.0	70.7	
	•			JDN 2390 xx	15.9	22.5	31.8	39.0	45.0	50.3	59.6	71.2	101	
	•			JDN 2590 xx	24.1	34.1	48.2	59.0	68.1	76.2	90.1	108	152	
65°		•		JDN 2780 xx	31.8	45.0	63.7	78.0	90.1	101	119	142	201	
			•	JEN 3158 xx	64.5	91.2	129	158	182	204	241	288	408	
	•			JFN 3195 xx	79.6	113	159	195	225	252	298	356	503	
	•			JFN 3230 xx	93.9	133	188	230	266	297	351	420	594	
80°	•			JDR 2195 xx	7.96	11.3	15.9	19.5	22.5	25.2	29.8	35.6	50.3	
	•			JDR 2240 xx	9.80	13.9	19.6	24.0	27.7	31.0	36.7	43.8	62.0	
	•			JDR 2274 xx	11.2	15.8	22.4	27.4	31.6	35.4	41.9	50.0	70.7	
	•			JDR 2390 xx	15.9	22.5	31.8	39.0	45.0	50.3	59.6	71.2	101	
	•			JDR 2590 xx	24.1	34.1	48.2	59.0	68.1	76.2	90.1	108	152	
95°			•	JFR 2780 xx	31.8	45.0	63.7	78.0	90.1	101	119	142	201	
	•			JDT 2195 xx	7.96	11.3	15.9	19.5	22.5	25.2	29.8	35.6	50.3	
	•			JDT 2240 xx	9.80	13.9	19.6	24.0	27.7	31.0	36.7	43.8	62.0	
	•			JDT 2274 xx	11.2	15.8	22.4	27.4	31.6	35.4	41.9	50.0	70.7	
	•			JDT 2390 xx	15.9	22.5	31.8	39.0	45.0	50.3	59.6	71.2	101	

### SPRAY ANGLE CODES

NOZZLE CODE	SPRAY ANGLE
JDA	0°
JDB	15°
JDD	25°
JDL	40°
JDN	50°
JDR	65°
JDT	80°
JDV	95°

DIMENSIONS AND WEIGHTS  
Below are dimensions and specifications for use.

CODE	Dim.	H	H1	WS	W
	inch	mm	mm	mm	gr
JD	1/2"	33	17	22	65
JE	3/4"	41	20	27	130
JF	1"	61	22	27	215

TYPICAL APPLICATIONS  
*Washing:* tanks, large parts and vehicles cleaning  
*Spray:* spray of chemicals, disinfectants and lubricating fluids  
*Cooling:* parts cooling, steel cooling  
*Other applications:* water curtain to separate toxic gases, fire-fighting systems

### HOW TO MAKE UP THE NOZZLE CODE

Ex.: JDA 2590 B1

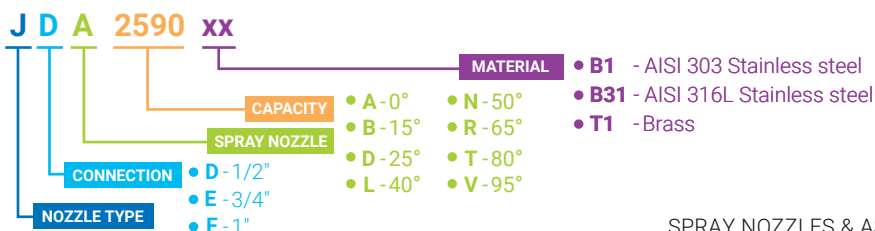

# K ( FLAT FAN NOZZLES / LARGE SPRAY ANGLE )

## LARGE SPRAY ANGLE

K flat fan nozzles work on the deflection principle conveying a water vein onto a machined deflection surface, and produce a jet with a wide angle flat spray pattern, medium impact value and medium size droplets. Between their inlet orifice and spray orientation there is a 75° angle (see below). Their round outlet orifice and free inside passage minimize the risk of clogging. In addition, compared to standard flat fan nozzles working with a limited operating pressure, the K series models with large spray angles produce an excellent mist effect. These K nozzles are available with threaded connections, for capacities from 0390 and 3350, and also as tips to be assembled onto a nipple by means of a retaining nut. An alternative option are the KX types.

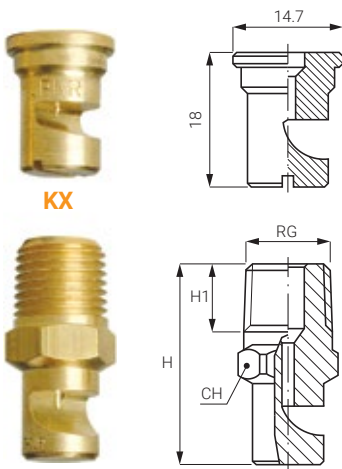

THREAD SPECIFICATION: BSPT, NPT

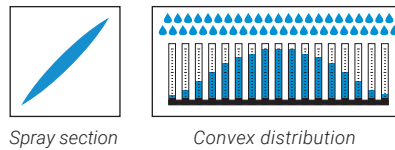

## THREAD SIZE AND DIMENSIONS

Here below please find available thread sizes and nozzles dimensions. Different capacities correspond to different deflection angles. The external dimensions may differ even if the thread size is the same. The table includes the largest nozzles with a given thread size.

CODE	RG inch	H mm	H1 mm	CH mm
KGW	1/8"	24,0 (from 0390 to 1120)	8,5	12
		25,0 (from 1160 to 1940)	9,0	
		31,0 (from 2117 to 2157)	10,0	
KHW	1/4"	31,0 (from 1160 to 1940)	12,5	14
		34,0 (from 2117 to 2210)		
KIW	3/8"	44,0 (all codes)	13,0	17
KJW	1/2"	49,0 (all codes)	17,0	22
KKW	3/4"	56,0 (from 2700 to 2940)	20,0	27
		65,0 (from 3110 to 3164)		36
KLW	1"	92,0 (all codes)	26,0	46

## ASSEMBLY FITTINGS

The below illustration shows the assembly of a KX nozzle tip (in the middle) with a nipple and a locknut.

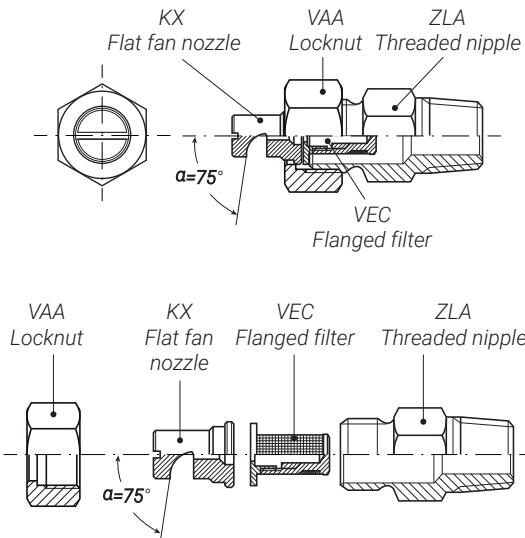

## Typical applications

- Washing: fruits, vegetables, crushed stones, other
- Spray: rolling oil, release agents, coolants
- Cooling: metal parts, bottles
- Other applications: foam dispersion, fire-fighting systems, water curtains

### HOW TO MAKE UP THE NOZZLE CODE

Ex.: KGW 0390 B1

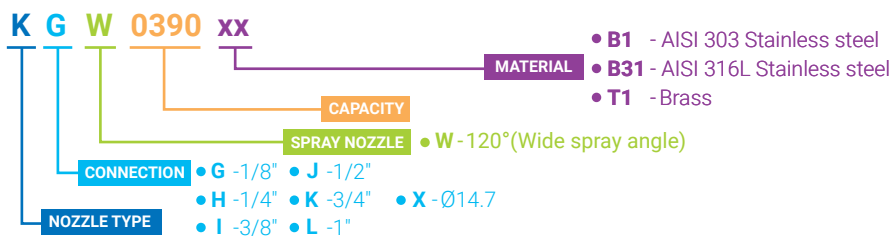





( FLAT FAN NOZZLES / LARGE SPRAY ANGLE ) **K**

LARGE SPRAY ANGLE

KGW 1/8"	KHW 1/4"	KIW 3/8"	KJW 1/2"	KKW 3/4"	KLW 1"	KXW	D mm	CODE	Capacity at different pressure values							Spray angle (°) at pressure (bar)	
									0.5	1.0	2.0	3.0	4.0	5.0	7.0	1.5	4.0
•						•	0.6	<b>0390</b>	0.16	0.23	0.32	0.39	0.45	0.50	0.60	90°	120°
•						•	0.7	<b>0590</b>	0.24	0.34	0.48	0.59	0.68	0.76	0.90	105°	120°
•						•	0.8	<b>0780</b>	0.32	0.45	0.64	0.78	0.90	1.01	1.19	110°	125°
•						•	1.0	<b>1120</b>	0.49	0.69	0.98	1.20	1.39	1.55	1.83	105°	122°
•	•					•	1.1	<b>1160</b>	0.65	0.92	1.31	1.60	1.85	2.07	2.44	110°	130°
•	•					•	1.3	<b>1200</b>	0.82	1.15	1.63	2.00	2.31	2.58	3.06	120°	130°
•	•					•	1.4	<b>1230</b>	0.94	1.33	1.88	2.30	2.66	2.97	3.51	110°	125°
•	•					•	1.6	<b>1310</b>	1.27	1.79	2.53	3.10	3.58	4.00	4.74	120°	130°
•	•					•	1.8	<b>1390</b>	1.59	2.25	3.18	3.90	4.50	5.03	5.96	130°	140°
•	•					•	2.3	<b>1590</b>	2.41	3.41	4.82	5.90	6.81	7.62	9.01	120°	130°
•	•					•	2.6	<b>1780</b>	3.18	4.50	6.37	7.80	9.01	10.1	11.9	130°	140°
•	•					•	2.9	<b>1940</b>	3.84	5.43	7.68	9.40	10.9	12.1	14.4	140°	150°
•	•					•	3.3	<b>2117</b>	4.78	6.75	9.55	11.7	13.5	15.1	17.9	110°	120°
•	•					•	3.6	<b>2141</b>	5.76	8.14	11.5	14.1	16.3	18.2	21.5	120°	130°
•	•					•	3.8	<b>2157</b>	6.41	9.06	12.8	15.7	18.1	20.3	24.0	120°	130°
	•					•	4.0	<b>2172</b>	7.02	9.93	14.0	17.2	19.9	22.2	26.3	125°	135°
	•					•	4.1	<b>2188</b>	7.68	10.9	15.4	18.8	21.7	24.3	28.7	130°	140°
	•					•	4.4	<b>2210</b>	8.57	12.1	17.1	21.0	24.2	27.1	32.1	135°	145°
		•				•	4.5	<b>2230</b>	9.39	13.3	18.8	23.0	26.6	29.7	35.1	110°	120°
		•				•	5.0	<b>2270</b>	11.0	15.6	22.0	27.0	31.2	34.9	41.2	115°	125°
		•	•			•	5.3	<b>2310</b>	12.7	17.9	25.3	31.0	35.8	40.0	47.4	125°	135°
		•	•				5.6	<b>2350</b>	14.3	20.2	28.6	35.0	40.4	45.2	53.5	130°	140°
			•				6.0	<b>2390</b>	15.9	22.5	31.8	39.0	45.0	50.3	59.6	130°	140°
			•				6.5	<b>2470</b>	19.2	27.1	38.4	47.0	54.3	60.7	71.8	135°	140°
			•				7.1	<b>2550</b>	22.5	31.8	44.9	55.0	63.5	71.0	84.0	135°	145°
			•				7.5	<b>2630</b>	25.7	36.4	51.4	63.0	72.7	81.3	96.2	140°	150°
				•			8.0	<b>2700</b>	28.6	40.4	57.2	70.0	80.8	90.4	107	130°	140°
				•			8.4	<b>2780</b>	31.8	45.0	63.7	78.0	90.1	101	119	135°	145°
				•			8.7	<b>2860</b>	35.1	49.7	70.2	86.0	99.3	111	131	135°	145°
				•			9.3	<b>2940</b>	38.4	54.3	76.8	94.0	109	121	144	140°	150°
				•			10.3	<b>3110</b>	44.9	63.5	89.8	110	127	142	168	125°	135°
				•			11.0	<b>3125</b>	51.0	72.2	102	125	144	161	191	130°	135°
				•			11.4	<b>3141</b>	57.6	81.4	115	141	163	182	215	130°	135°
				•			12.2	<b>3164</b>	67.0	94.7	134	164	189	212	251	135°	145°
					•		14.6	<b>3235</b>	95.9	136	192	235	271	303	359	130°	135°
					•		17.9	<b>3350</b>	143	202	286	350	404	452	535	130°	135°

ASSEMBLY FITTINGS

KX series nozzles are assembled with pipe clamp, welding nipple and locknut.  
Our assembly accessories are available in many different types and materials.

Name	Material code	Appearance	Model no.	
			3/8" Standard size	3/4" Large size
Locknut <i>P.90</i>	<b>B1</b> - AISI 303 <b>B31</b> - AISI 316L <b>T1</b> - Brass <b>D6</b> - Fiberglass reinforced PP		VAA 0380 <b>xxB</b>	VAA 0750 <b>xxB</b>
Welding nipple <i>P.91</i>	<b>B1</b> - AISI 303 <b>B31</b> - AISI 316L		ZAA C018 <b>xxG</b>	ZAA E027 <b>xxG</b>
Threaded nipple <i>P.91</i>	<b>B1</b> - AISI 303 <b>B31</b> - AISI 316L <b>T1</b> - Brass		ZLA 2538 <b>xxB</b>	ZLA 7575 <b>xxB</b>
Metal pipe clamp <i>P.89</i>	<b>B1</b> - AISI 303 <b>T1</b> - Brass		ZPM	-
Plastic pipe clamp <i>P.88</i>	<b>D6</b> - Fiberglass reinforced PP		ZPB 0050 D6	-



# K (FLAT FAN NOZZLES / HIGH IMPACT TYPES)

## HIGH IMPACT TYPES

The K series nozzles of this type are designed with a spoon-shaped deflected surface to concentrate the liquid flow and produce a narrow-angle flat fan spray with a high impact value. For this feature they are widely used in all working environments requiring powerful jets. Compared to the standard cat-eye-shaped flat fan nozzle tips, K nozzles have a larger and free inner passage and are less subject to clogging, provide high performance cleaning efficiency and have an extended operating life. They are designed with a specific angle (see ~ CL on the left drawing) between inlet orifice and spray orientation surface. These nozzles are available with standard male threads but also with quick coupling nipples to shorten maintenance time.

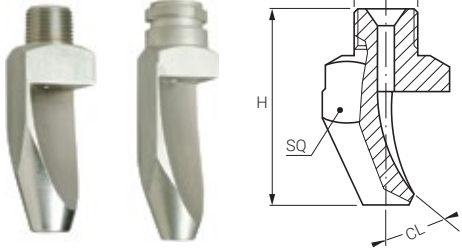

THREAD SPECIFICATION: BSPT, NPT

### TYPICAL APPLICATIONS

cleaning of parts, crushed stone, road, aircrafts, vehicles and tanks.



Spray section

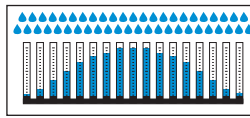

Convex distribution



### THREAD SIZE CODE

<b>KOx</b>	1/8"
<b>KPx</b>	1/4"
<b>KQx</b>	3/8"
<b>KRx</b>	1/2"
<b>KSx</b>	3/4"
<b>KTx</b>	QC

### QUICK COUPLING NIPPLES

Name	Thread size (RG) inch	Standard size	Large size	H mm	CH mm	DIA mm
Male nipple	1/4"	ZHS 0025 <b>xx</b> Q1	-	29	22	-
	3/8"	ZHS 0038 <b>xx</b> Q1	-	29	22	-
	1/2"	-	ZHS 0050 <b>xx</b> Q2	35	30	-
Female nipple	3/8"	ZHT 0038 <b>xx</b> Q1	-	29	22	-
Welding nipple	-	ZHU 0038 <b>xx</b> Q1	ZHU 0050 <b>xx</b> Q2	32	-	28
Seal (Viton) for SS nipple	-	VDH BQ10 E7	VDH BQ20 E7	-	-	-
Seal (BUNA) for brass nipple	-	VDH BQ10 E8	VDH BQ20 E8	-	-	-



ZHS + KTH



ZHS 0025 **xx**Q1



ZHS 0050 **xx**Q2

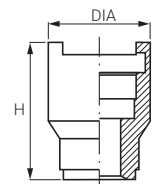
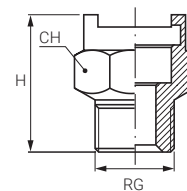

ZHU 0038 **xx**Q1

### HOW TO MAKE UP THE NOZZLE CODE

EX.: KPB 1390 B1

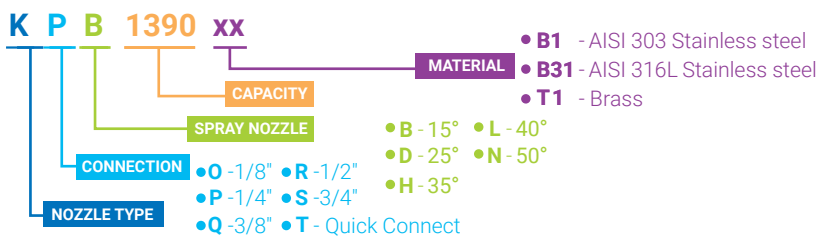



( FLAT FAN NOZZLES / HIGH IMPACT TYPES ) **K**

HIGH IMPACT TYPES

15°	1/8"	1/4"	3/8"	1/2"	3/4"	QC	CODE	D mm	Capacity at different pressure values (l/min) (bar)							CL deg	H mm	SQ mm		
									2.0	3.0	4.0	5.0	6.0	7.0	10					
15°		KPB					KTB	1.9	3.18	3.90	4.50	5.03	5.52	5.96	7.12	22°	48	15		
		KPB					KTB	2.6	6.37	7.80	9.01	10.1	11.0	11.9	14.2	19°	54			
			KQB					KTB	3.2	9.55	11.7	13.5	15.1	16.5	17.9	21.4	25°	72	20	
			KQB					KTB	3.7	12.7	15.6	18.0	20.1	22.1	23.8	28.5	18°	92		
			KQB					KTB	4.2	15.9	19.5	22.5	25.2	27.6	29.8	35.6	15°	90		
				KRB					4.6	18.8	23.0	26.6	29.7	32.5	35.1	42.0	14°	125	25	
				KRB					5.3	25.3	31.0	35.8	40.0	43.8	47.4	56.6	14°	130		
				KRB		KSB			5.9	31.8	39.0	45.0	50.3	55.2	59.6	71.2	14°	137		
					KSB			8.4	63.7	78.0	90.1	101	110	119	142	14°	191	30		
25°		KPD					KTD	3.7	12.7	15.6	18.0	20.1	22.1	23.8	28.5	25°	65	20		
35°	KOH						KTH	1.2	1.31	1.60	1.85	2.07	2.26	2.44	2.92	40°	23	12		
			KPH					KTH	1.9	3.18	3.90	4.50	5.03	5.52	5.96	7.12	36°	37	15	
			KPH	KQH					KTH	2.6	6.37	7.80	9.01	10.1	11.0	11.9	14.2	30°	43	20
			KPH	KQH					KTH	2.9	8.00	9.80	11.3	12.7	13.9	15.0	17.9	28°	49	
			KPH	KQH					KTH	3.3	9.55	11.7	13.5	15.1	16.5	17.9	21.4	28°	52	
				KQH					KTH	3.7	12.7	15.6	18.0	20.1	22.1	23.8	28.5	26°	58	
				KQH					KTH	4.1	15.9	19.5	22.5	25.2	27.6	29.8	35.6	23°	64	
					KRH				KTH	4.5	18.8	23.0	26.6	29.7	32.5	35.1	42.0	22°	73	25
					KRH				KTH	5.3	25.3	31.0	35.8	40.0	43.8	47.4	56.6	24°	81	
					KRH					5.9	31.8	39.0	45.0	50.3	55.2	59.6	71.2	19°	89	
						KSH				7.5	51.4	63.0	72.7	81.3	89.1	96.2	115	23°	114	32
						KSH				8.4	63.7	78.0	90.1	101	110	119	142	22°	122	
40°			KQL				KTL	3.7	12.7	15.6	18.0	20.1	22.1	23.8	28.5	35°	60	25		
			KQL				KTL	4.1	15.9	19.5	22.5	25.2	27.6	29.8	35.6	33°	64			
			KQL					KTL	4.5	18.8	23.0	26.6	29.7	32.5	35.1	42.0	33°	72		
			KQL					KTL	5.0	22.0	27.0	31.2	34.9	38.2	41.2	49.3	29°	75		
			KQL					KTL	5.2	25.3	31.0	35.8	40.0	43.8	47.4	56.6	26°	77		
			KQL					KTL	5.7	28.6	35.0	40.4	45.2	49.5	53.5	63.9	28°	77		
			KQL					KTL	6.0	31.8	39.0	45.0	50.3	55.2	59.6	71.2	28°	87		
50°		KPN	KQN				KTN	1.5	1.63	2.00	2.31	2.58	2.83	3.06	3.65	50°	31	15		
		KPN	KQN				KTN	1.6	2.20	2.70	3.12	3.49	3.82	4.12	4.93	50°	31			
		KPN	KQN				KTN	1.9	3.18	3.90	4.50	5.03	5.52	5.96	7.12	60°	31			
		KPN	KQN				KTN	2.9	8.00	9.80	11.3	12.7	13.9	15.0	17.9	42°	41	20		
		KPN	KQN				KTN	3.7	12.7	15.6	18.0	20.1	22.1	23.8	28.5	45°	47			
		KPN	KQN				KTN	4.5	18.8	23.0	26.6	29.7	32.5	35.1	42.0	37°	55	25		
			KQN					KTN	6.0	31.8	39.0	45.0	50.3	55.2	59.6	71.2	40°	72	30	
			KQN					KTN	6.7	40.0	49.0	56.6	63.3	69.3	74.8	89.5	38°	72		
			KQN					KTN	7.5	51.4	63.0	72.7	81.3	89.1	96.2	115	37°	72		
			KQN					KTN	8.4	63.7	78.0	90.1	101	110	119	142	32°	72		

HOW TO MAKE UP THE NOZZLE CODE

Ex.: KPB 1390 B1

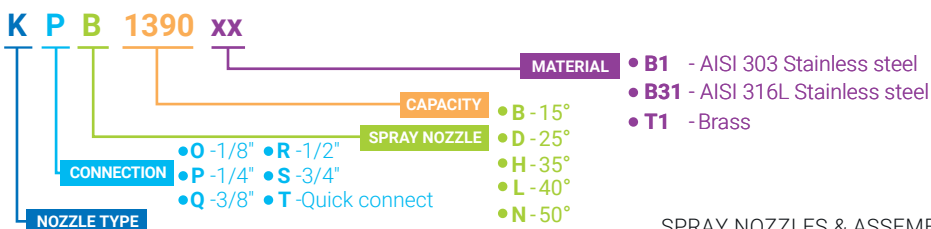

# SHOWER PIPE

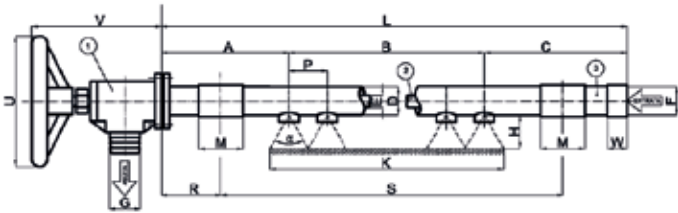

**LEGEND**

- A: first nozzle position
- B: nozzle span
- C: last nozzle position
- D: external diameter x pipe width
- E: shaft outer diameter
- F: inlet connection
- G: outlet connection
- H: height
- L: standard reference length
- M: support length
- N: nozzles number
- P: nozzle pitch
- R: support position
- S: sleeve span
- U: hand wheel diameter
- V: valve length
- W: nipple length
- α: spray angle
- (1): assy valve
- (2): assy shaft
- (3): assy pipe

The following table shows the minimum and the maximum values, for the pipes already produced by PNR Italia.

DIM.	MIN	MAX
D (mm)	Ø 50 x 1.5	Ø 73 x 3
L (mm)	600	7100
A (mm)	200	735
B (mm)	200	6000
C (mm)	200	1350
N	2	51
P (mm)	80	2950
F (inch)	1-1/2" F	2-1/2" F
G (mm)	Ø 48	Ø 60

The images shows the functioning of the self-cleaning shower pipe, while rotating the wheel.

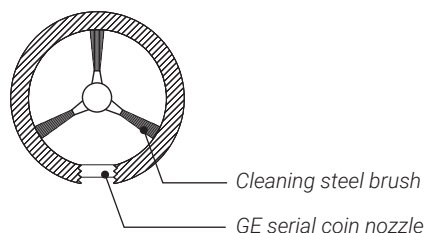

## SELF-CLEANING SHOWER PIPES

Self-cleaning shower pipes are used in the pulp and paper industry for washing and cleaning forming fabrics and felts. There are two kinds of pipes:

- Low pressure (2 ÷ 6 bar) fixed pipes with flat fan nozzles (PNR nozzle: GE)
- High pressure (25 ÷ 70 bar) oscillating pipes with straight jet nozzles (PNR nozzles: GEA)

Both fixed and oscillating pipes must have the following characteristics:

- presence of a cleaning system that cleans the nozzles with simultaneous discharge of impurities;
- easy and fast activation of the cleaning system, without interrupting the spray and without problems for the operators;
- usage of nozzles that allow to save water and that never get blocked, eventually after a long

Shower pipes that satisfy these three characteristics have a structure made of three main parts.

The **Assy Valve** must allow the passage or the stop of the discharge flux, through the opening or the closing of a lock, moved by a shaft, manually activated by a hand wheel. This movement is used to activate the Assy Shaft. The Assy Valve is connected to the Assy Pipe through a flanged connection, and to the discharge pipes through a specific connection (thread or hose fitting).

The **Assy Shaft** is made by a pipe with specific brushes mounted on it; thanks to the connection with the shaft of the Assy Valve, it moves radially and axially. In this way, the brushes can remove the impurities both from the nozzles and from the inner part of the Assy Pipe.

The nozzles are assembled on the **Assy Pipe**, which is connected to the main pipe. Nozzles can be installed with specific welding nipples or through plastic pipe clamps (PNR code: ZPH, see page 90).

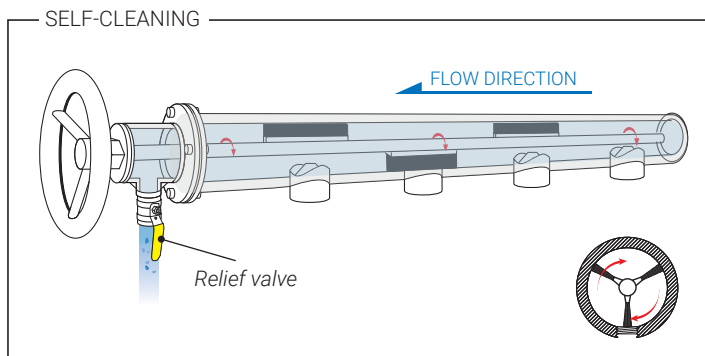
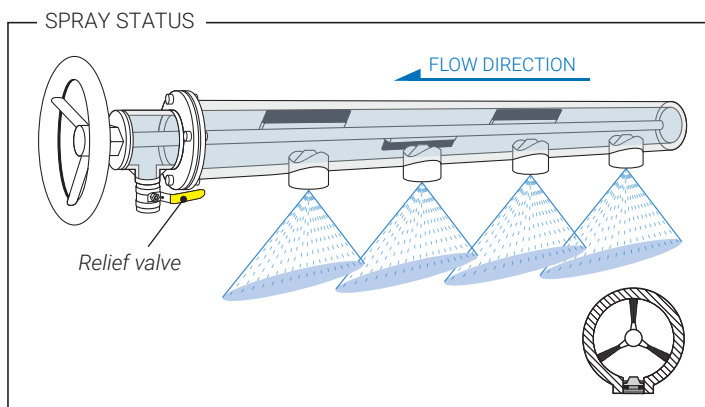

# ( FLAT FAN NOZZLES / DISC NOZZLES ) GE

## FLAT FAN NOZZLES / DISC NOZZLES

In GE series disc nozzles with thickness 1.2 mm the spray jet is close to the turbulence structure and this special design makes them very easy to clean. Within the delivery pipe these nozzles are assembled to a steel brush, that can be manually or automatically rotated, which takes off all the dirt washed out by water and then flushed out through a release valve positioned at the end of the pipe. Disc nozzles, with their special low profile design, can be easily removed for cleaning so they reduce maintenance times and costs and improve the plant efficiency.

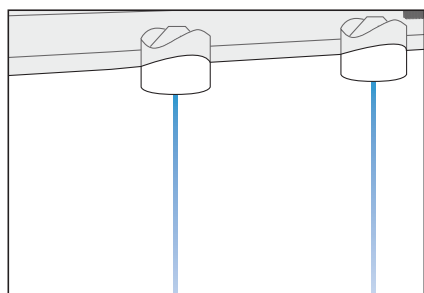

**TYPICAL APPLICATIONS**  
Washing or spraying in pulp and paper mills, mesh fabrics cleaning, water treatment systems, screen and filter (felt and wire) washing and more.



Spray section

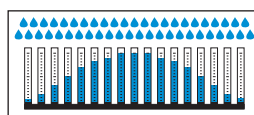

Convex distribution



Spray angle	CODE	D1 mm	Capacity at different pressure values (l/min) (bar)					
			3.0	4.0	6.0	10	15	20
60°	GEQ 0900 xx	1.0	<b>0.90</b>	1.04	1.27	1.64	2.01	2.32
	GEQ 1170 xx	1.5	<b>1.70</b>	1.96	2.40	3.10	3.80	4.39
	GEQ 1234 xx	1.7	<b>2.34</b>	2.70	3.31	4.27	5.23	6.04
	GEQ 1310 xx	2.0	<b>3.10</b>	3.58	4.38	5.66	6.93	8.00
	GEQ 1490 xx	2.5	<b>4.90</b>	5.66	6.93	8.95	11.0	12.7
	GEQ 1780 xx	3.0	<b>7.80</b>	9.01	11.0	14.2	17.4	20.1
	GEQ 2124 xx	4.0	<b>12.4</b>	14.3	17.5	22.6	27.7	32.0
	GEQ 2194 xx	5.0	<b>19.4</b>	22.4	27.4	35.4	43.4	50.1
GEQ 2310 xx	7.0	<b>23.0</b>	26.6	32.5	42.0	51.4	59.4	
75°	GES 0900 xx	1.0	<b>0.90</b>	1.04	1.27	1.64	2.01	2.32
	GES 1170 xx	1.5	<b>1.70</b>	1.96	2.40	3.10	3.80	4.39
	GES 1234 xx	1.7	<b>2.34</b>	2.70	3.31	4.27	5.23	6.04
	GES 1310 xx	2.0	<b>3.10</b>	3.58	4.38	5.66	6.93	8.00
	GES 1490 xx	2.5	<b>4.90</b>	5.66	6.93	8.95	11.0	12.7
	GES 1780 xx	3.0	<b>7.80</b>	9.01	11.0	14.2	17.4	20.1
	GES 2124 xx	4.0	<b>12.4</b>	14.3	17.5	22.6	27.7	32.0
	GES 2194 xx	5.0	<b>19.4</b>	22.4	27.4	35.4	43.4	50.1
GES 2310 xx	7.0	<b>23.0</b>	26.6	32.5	42.0	51.4	59.4	

### FLAT FAN NOZZLES

HOW TO MAKE UP THE NOZZLE CODE Ex.: GES 1310 C7MV

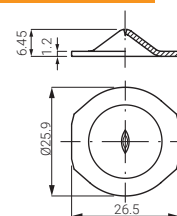

Flat fan nozzle - US  
GES 1310 C7SV

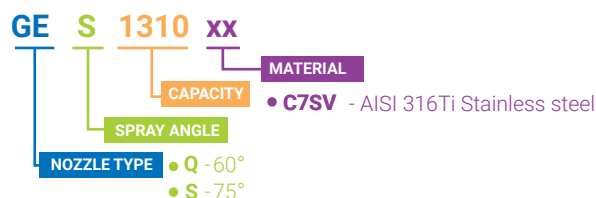

### GEA SERIAL STRAIGHT NOZZLES

D mm	Nozzle type		CODE	Capacity at different pressure values (l/min) (bar)					
	Stainless steel	Ruby insert		3.0	4.0	6.0	10	15	20
0.55	•	•	<b>0300</b>	<b>0.30</b>	0.35	0.42	0.55	0.67	0.77
0.38	•	•	<b>0380</b>	<b>0.12</b>	0.14	0.17	0.22	0.27	0.31
0.80	•	•	<b>0500</b>	<b>0.50</b>	0.58	0.71	0.91	1.12	1.29
0.63	•	•	<b>0630</b>	<b>0.34</b>	0.39	0.48	0.62	0.76	0.88
0.81	•	•	<b>0810</b>	<b>0.50</b>	0.58	0.71	0.91	1.12	1.29
1.00	•	•	<b>0900</b>	<b>0.90</b>	1.04	1.27	1.64	2.01	2.32
0.91	•	•	<b>0910</b>	<b>0.70</b>	0.81	0.99	1.28	1.57	1.81
1.02	•	•	<b>1010</b>	<b>0.88</b>	1.02	1.24	1.61	1.97	2.27
1.20	•	•	<b>1130</b>	<b>1.30</b>	1.50	1.84	2.37	2.91	3.36
1.30	•	•	<b>1170</b>	<b>1.70</b>	1.96	2.40	3.10	3.80	4.39
1.19	•	•	<b>1200</b>	<b>1.03</b>	1.19	1.46	1.88	2.30	2.66
2.00	•	•	<b>1310</b>	<b>3.10</b>	3.58	4.38	5.66	6.93	8.00

### STRAIGHT JET NOZZLES

HOW TO MAKE UP THE NOZZLE CODE Ex.: GEA 0900 C7S

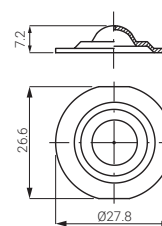

Metal  
GEA 0900 C7S

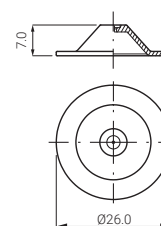

Ruby nozzle tip  
GEA 0900 F31

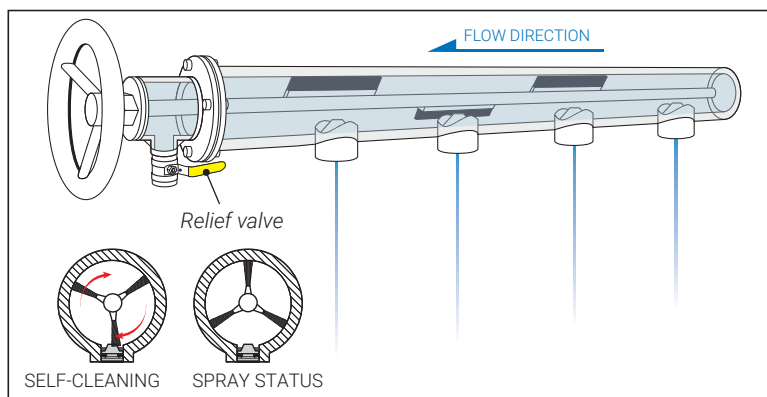
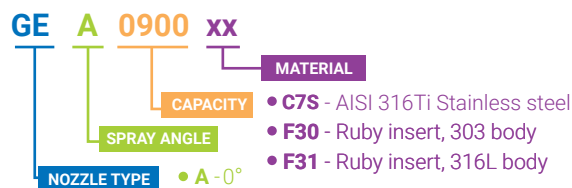

# GF ( FLAT FAN NOZZLES / SELF-CLEANING NOZZLES )

## GF SERIES SELF-CLEANING NOZZLES



The self-cleaning design of the GF series nozzles allow an easy maintenance of cleaning spray bars and shower headers. The nozzle body contains a mobile piston whose opening and closure is operated by the water pressure. For example, when nozzles wash mesh fabrics with an operating pressure of 3.0 bar, this pressure is higher than a spring force of 1.0 bar. Piston and nozzle body come close producing a flat fan spray. If the inlet pressure is reduced to 0.5 bar, lower than a spring force of 1.0 bar, piston and nozzle body separate opening to the maximum distance. Water pressure remains at 0.5 bar and removes any build up when back to normal condition. In a word, to clean these nozzles it's sufficient to reduce pressure to avoid the accumulation of dirt inside. GF self-cleaning nozzles are easy to install, align and clean ensuring relevant time and costs savings. The spring force is set depending on customer's plant working pressure.

### TYPICAL APPLICATIONS

Washing or spraying in pulp and paper mills, mesh fabrics cleaning, water treatment systems, and more.



Spray section

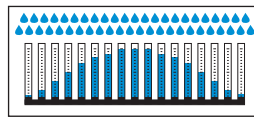

Convex distribution

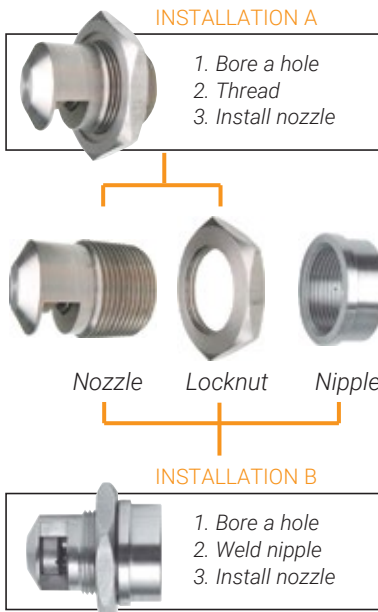
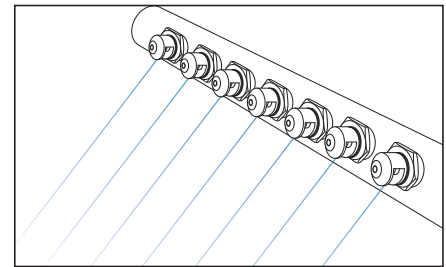

ANGLE	CODE	Capacity at different pressure values (l/min) (bar)								
		3.0	4.0	5.0	6.0	7.0	8.0	10	15	20
0°	GFA 1100 B31 xx	1.00	1.15	1.29	1.41	1.53	1.63	1.83	2.24	2.58
	GFA 1235 B31 xx	2.35	2.71	3.03	3.32	3.59	3.84	4.29	5.25	6.07
	GFA 1330 B31 xx	3.30	3.81	4.26	4.67	5.04	5.39	6.02	7.38	8.52
45°	GFM 1630 B31 xx	6.30	7.27	8.13	8.91	9.62	10.3	11.5	14.1	16.3
	GFM 1750 B31 xx	7.50	8.66	9.68	10.6	11.5	12.2	13.7	16.8	19.4
	GFM 1970 B31 xx	9.70	11.2	12.5	13.7	14.8	15.8	17.7	21.7	25.0
	GFM 2121 B31 xx	12.1	14.0	15.6	17.1	18.5	19.8	22.1	27.1	31.2
60°	GFM 2139 B31 xx	13.9	16.1	17.9	19.7	21.2	22.7	25.4	31.1	35.9
	GFQ 1630 B31 xx	6.30	7.27	8.13	8.91	9.62	10.3	11.5	14.1	16.3
	GFQ 1750 B31 xx	7.50	8.66	9.68	10.6	11.5	12.2	13.7	16.8	19.4
	GFQ 1970 B31 xx	9.70	11.2	12.5	13.7	14.8	15.8	17.7	21.7	25.0
80°	GFQ 2121 B31 xx	12.1	14.0	15.6	17.1	18.5	19.8	22.1	27.1	31.2
	GFQ 2139 B31 xx	13.9	16.1	17.9	19.7	21.2	22.7	25.4	31.1	35.9
	GFT 1630 B31 xx	6.30	7.27	8.13	8.91	9.62	10.3	11.5	14.1	16.3
	GFT 1750 B31 xx	7.50	8.66	9.68	10.6	11.5	12.2	13.7	16.8	19.4
	GFT 1970 B31 xx	9.70	11.2	12.5	13.7	14.8	15.8	17.7	21.7	25.0
	GFT 2121 B31 xx	12.1	14.0	15.6	17.1	18.5	19.8	22.1	27.1	31.2
	GFT 2139 B31 xx	13.9	16.1	17.9	19.7	21.2	22.7	25.4	31.1	35.9

Thread specification	M28 x 1.5	3/4" - 20 UNEF	1 1/8" - 18 UNEF	3/4" BSP
Nozzle	GFx xxxx B31SM	GFx xxxx B31SN	GFx xxxx B31SP	GFx xxxx B31SG
Nipple	XGF 2832 B31SM	XGF 2832 B31SN	XGF 2832 B31SP	XGF 2832 B31SG
Locknut	XGF 7010 B31SM	XGF 7010 B31SN	XGF 7010 B31SP	XGF 7010 B31SG

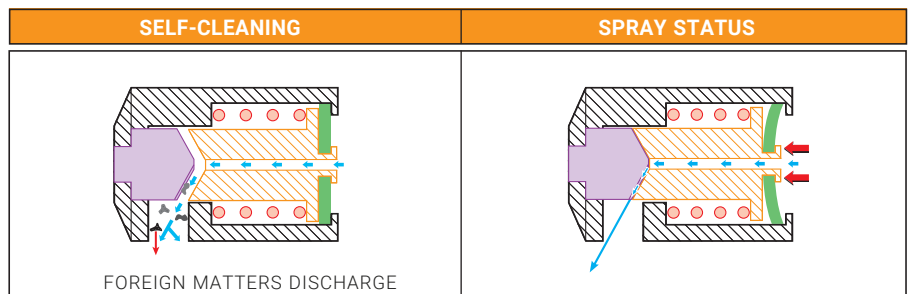
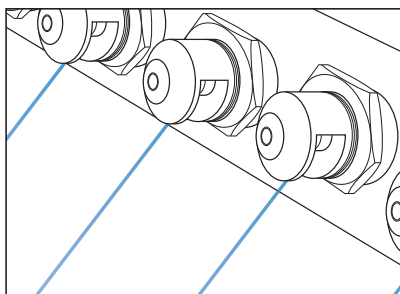

**HOW TO MAKE UP THE NOZZLE CODE**  
Ex.: GFA 1100 B31SM

